



4800 Ashford Dunwoody Road
 Dunwoody, GA 30338
 Phone: (678) 382-6800
 dunwoodyga.gov

MEMORANDUM

To: Mayor and City Council

From: Madalyn Smith, Senior Planner

Date: August 14, 2023

Subject: RZ 23-01 & SLUP 23-01 – 4470 Chamblee Dunwoody Road, Parcel ID# 18 345 03 017

REQUEST

The applicant, Coro Realty Advisors, requests to rezone the subject property from O-I to O-D. Additionally, the applicant requests a Special Land Use Permit to increase the maximum allowable height from 2 stories to 4 stories, for the construction of a new self-storage facility.

APPLICANT

Property Owner: JHH 4470 Chamblee Dunwoody, LLC	Petitioner: Coro Realty Advisors	Representative: Dennis Webb, Jr. (Smith, Gambrell & Russell, LLP)
---	-------------------------------------	---

CITY COUNCIL, 7.10.23

City Council held a second read regarding the subject cases on July 10, 2023.

The City Council provided feedback regarding the proposed renderings; a landscape plan was also requested. The applicant’s requested deferral of consideration to the August 14th meeting was granted.

In response to the feedback provided by Council, the applicant submitted updated renderings and a landscape plan.

UPDATED APPLICATION MATERIALS

- *Updated Renderings, submitted July 27, 2023:* The new rendering demonstrates compliance with the Georgetown design guidelines (see img. 1). Additionally, as opposed to the previous design, the current design utilizes a more traditional design language.



Img. 1, Current rendering of proposed building



Img. 2, Previous rendering of proposed building

- *Site Plan & Landscape Plan, dated July 21, 2023:* The plans demonstrate compliance with the required transition buffer. The landscape plan shows the proposed conditions for the former office building site (adjacent to I-285) as a grassed area.

CITY COUNCIL, 6.12.23

City Council held a public hearing regarding the subject cases on June 12, 2023.

The City Council discussed the appropriateness of the proposed self-storage use and the architecture of the proposed building. The Council requested that the applicant consider an alternative design for the building. To accommodate, the applicant has requested deferral of the consideration of RZ 23-01 and SLUP 23-01 to the August 14th meeting. Since that meeting, the applicant has explored different architectural options and has updated the design and renderings.

PLANNING COMMISSION, 4.11.23

Planning Commission held a public hearing regarding the subject cases on April 11, 2023. There were no public comments.

The Planning Commission discussed the location of loading docks, site lighting, easement language, and staff's condition that required the closing of a curb cut. Ultimately, Erika Harris moved to defer consideration of RZ 23-01 & SLUP 23-01 to the May 9, 2023 Planning Commission meeting, to allow time for legal counsel on proposed condition #4 and to gather more information on site lighting and easement language; Deb Cameron seconded, motion passed.

Condition #4 stated "The southernmost curb-cut for 4478 Chamblee Dunwoody Road shall be closed, prior to the issuance of a Certificate of Occupancy for the subject self-storage facility at 4470 Chamblee-Dunwoody Road." Based on comments from the Planning Commission and staff's internal review, this condition has been removed.

PLANNING COMMISSION, 5.9.23

At the May 9, 2023 Planning Commission meeting Deb Cameron moved to approve RZ 23-01 subject to staff conditions, Elizabeth Shin seconded, and the motion passed 5-0. Deb Cameron then moved to approve SLUP 23-01 subject to staff condition, Elizabeth Shin seconded, and the motion passed 5-0.

BACKGROUND & PROPOSED DEVELOPMENT

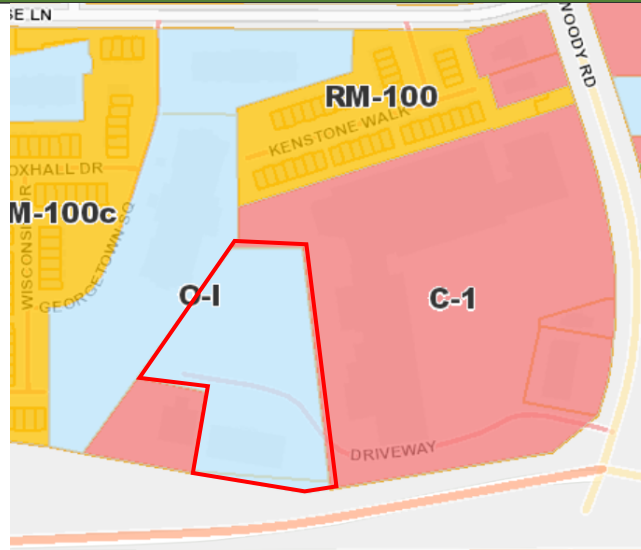

Fig. 1, Zoning Map

The subject property is currently zoned as Office-Institutional (O-I) and is located within the Georgetown Character Area. It is a 3.5-acre landlocked site, adjacent to I-285, which has access from

Chamblee Dunwoody Road via an access easement. It is located between the Georgetown Shopping Center and the Dunwoody Pines Retirement Community. Also in proximity to the site is the 54-unit townhome development, Georgetown Square. The property was previously developed with a 5-story office building, which has since been demolished as a result of the I-285 project. It is currently only a surface parking lot, with a buffer of mature trees along the north and eastern property lines. There is a small ridge along the eastern and south eastern portion of the site, and overall the property slopes down gently from east to west. There is a series of stormwater pipes that cross the site, feeding into a detention pond on an adjacent property.

The applicant proposes to construct a new four-story self-storage facility. Self-storage is not a permitted use within the O-I district and, as such, the subject application seeks to rezone the property to Office-Distribution (O-D). Additionally, within the O-D district, an approved special land use permit (SLUP) is required to exceed the maximum height of two stories, thus prompting the SLUP request.

SITE PLAN ANALYSIS

The subject application proposes two loading spaces and sidewalk improvements. On the northern half of the site, the applicant proposes to infill the existing surface parking lot with a 140,000 SF, four-story self-storage building and 12 surface parking spaces. The applicant also proposes to improve and extend the sidewalk and provide a stub-out for future connection across the western property line. The building will be setback approximately 80 feet from the northern property line, 60 feet from the eastern property line, and 25 feet from the western property line; all within the required setbacks.

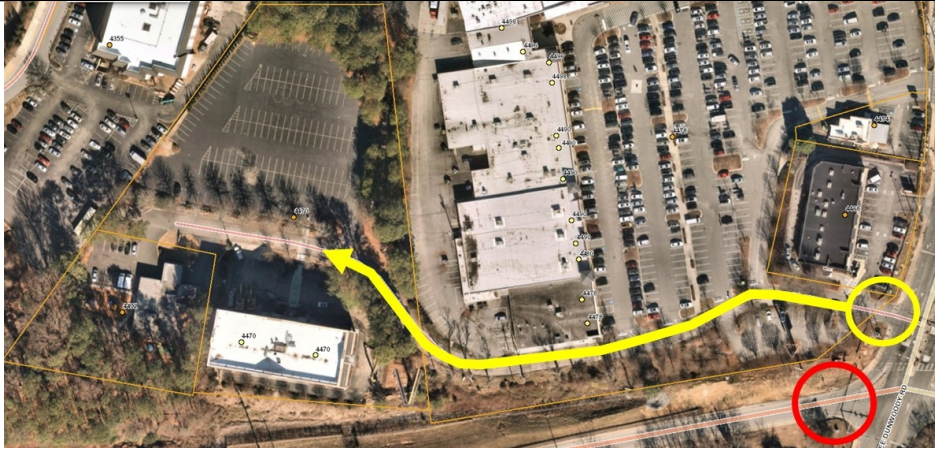

Figure 3. Access to the site

There are significant conflicts between this entrance and the I-285 on-ramp. Sec. 16-237(s)(5) of the Code of Ordinance, stipulates that access points must have a minimum spacing of 245 feet; these two access points only have 85 feet of separation. In accordance with the City’s access management plan, the curb cut should be closed and access be rerouted through another entrance on the property. As the access point is right-in/right-out only, it only has limited usefulness, with visitors likely using a different point of access for either going to or from the site. However, this is not a condition of approval for this specific zoning request, but staff recommends that the applicant consider their options for removing this unsafe condition.



Figure 4. Rendering of the proposed storage facility.

The building design is consistent with contemporary corporate architecture and the dominate façade materials are glass and brick. These building design and materials are consistent with the architectural design standards in the Georgetown Master Plan.

SURROUNDING LAND ANALYSIS			
Direction	Zoning	Future Land Use	Current Land Use
N	C-1	Commercial	Shopping Center
S	I-285		
E	C-1	Commercial	Shopping Center
W	O-I	Commercial	Retirement Home

ZONING AMENDMENT REVIEW AND APPROVAL CRITERIA

Chapter 27, Section 27-335 identifies criteria for evaluating applications for zoning amendments. No application for an amendment shall be granted by the City Council unless satisfactory provisions and arrangements have been made concerning each of the following factors, all of which are applicable to each application:

- (1) Whether the zoning proposal is in conformity with the policy and intent of the comprehensive plan;
- (2) Whether the zoning proposal will permit a use that is suitable in view of the use and development of adjacent and nearby properties;
- (3) Whether the property to be affected by the zoning proposal has a reasonable economic use as currently zoned;
- (4) Whether the zoning proposal will adversely affect the existing use or usability of adjacent or nearby property;
- (5) Whether there are other existing or changing conditions affecting the use and development of the property that provide supporting grounds for either approval or disapproval of the zoning proposal;
- (6) Whether the zoning proposal will adversely affect historic buildings, sites, districts, or archaeological resources; and
- (7) Whether the zoning proposal will result in a use that will or could cause an excessive or burdensome use of existing streets, transportation facilities, utilities, or schools.

The applicant proposes to rezone from O-I to O-D to accommodate a self-storage facility, which is not a permitted use within the O-I district. Though the zoning is changing, the proposed use is of lesser intensity than the previous office use.

The Comprehensive Plan and Georgetown Master Plan envision a pedestrian and bicycle-oriented activity center with limited impacts from commercial development on residential neighborhoods, less surface parking, and high quality design. Although a storage facility is not an active destination, it is a relatively unobtrusive use that is compatible with adjacent properties. It reduces surface parking, lays the groundwork for future connectivity with a new access easement at the western property line, and uses high-quality building materials.

The property does have the ability to be developed under the O-I regulations, but the specific proposal for a self-storage facility would not be permitted. The subject property is suited to this use because it is tucked away from the major activity centers. The site's lack of visibility from Chamblee Dunwoody Road limits the usage for more active uses. The nature of self-storage is that it is generally quiet and does not encourage street-level activity because it is not attracting pedestrians/cyclists or general visitors.

The redevelopment would not adversely affect any historic buildings or, to staff's knowledge, archaeological sites. A self-storage facility will not cause any additional burden to schools. The proposed facility is still relatively small and is not significant enough to trigger a traffic study, nor does staff anticipate any additional burden on streets or transportation facilities.

SPECIAL LAND USE PERMIT REVIEW AND APPROVAL CRITERIA

Chapter 27, Section 27-359 identifies criteria for evaluating applications for special land use permits. No application for special land use permit shall be granted by the City Council unless satisfactory provisions and arrangements have been made concerning each of the following factors, all of which are applicable to each application:

- (1) Whether the proposed use is consistent with the policies of the comprehensive plan;
- (2) Whether the proposed use complies with the requirements of this zoning ordinance;
- (3) Whether the proposed site provides adequate land area for the proposed use, including provision of all required open space, off-street parking and all other applicable requirements of the subject zoning district;
- (4) Whether the proposed use is compatible with adjacent properties and land uses, including consideration of:
 - a. Whether the proposed use will create adverse impacts upon any adjoining land use by reason of noise, smoke, odor, dust or vibration generated by the proposed use;
 - b. Whether the proposed use will create adverse impacts upon any adjoining land use by reason of the hours of operation of the proposed use;
 - c. Whether the proposed use will create adverse impacts upon any adjoining land use by reason of the manner of operation of the proposed use;
 - d. Whether the proposed use will create adverse impacts upon any adjoining land use by reason of the character of vehicles or the volume of traffic generated by the proposed use;
 - e. Whether the size, scale and massing of proposed buildings are appropriate in relation to the size of the subject property and in relation to the size, scale and massing of adjacent and nearby lots and buildings; and
 - f. Whether the proposed plan will adversely affect historic buildings, sites, districts, or archaeological resources.
- (5) Whether public services, public facilities and utilities—including motorized and nonmotorized transportation facilities—are adequate to serve the proposed use;
- (6) Whether adequate means of ingress and egress are proposed, with particular reference to nonmotorized and motorized traffic safety and convenience, traffic flow and control and emergency vehicle access;
- (7) Whether adequate provision has been made for refuse and service areas; and
- (8) Whether the proposed building as a result of its proposed height will create a negative shadow impact on any adjoining lot or building.

The applicant requests a SLUP to allow a 4-story building within the O-D district.

Overall, as discussed above, staff finds that the proposed 4-story self-storage facility is consistent with the comprehensive plan. The site plan shows that the proposed building meets all required setbacks and lot coverage requirements, and demonstrates compliance with the zoning ordinance without the need for a variance. It also shows loading dock facilities and a screened trash enclosure, so adequate service and refuse areas are provided.

A self-storage facility, by the nature of its operation, is not obtrusive. It does not generate excessive noise, smoke, odor, dust, vibration, or traffic. The height of the building is consistent with the office building that previously existed on the site, which was five stories. Additionally, the facility is adjacent to a shopping center that would not be affected by the additional height, and is also adjacent to a retirement home, which is taller than the proposed self-storage facility. As such, staff does not anticipate a negative shadow impact.

DEPARTMENT OF COMMUNITY DEVELOPMENT RECOMMENDATION

Staff recommends approval of the requested rezoning from O-I to O-D and recommends approval of the special land use permit to allow a height of 4-stories, subject to the following conditions:

- Exhibit A: Site Plan, prepared by Paradigm Engineering Services, Inc. and dated July 21, 2023
- Exhibit B: Elevations and Renderings, submitted July 27, 2023
- Exhibit C: Landscape Plan, prepared by Brunson & Company, and dated July 21, 2023

1. The applicant shall develop the site in general conformity with “Exhibit A”, “Exhibit B”, and “Exhibit C” with minor changes, and any additional changes allowed as defined by Section 27-337(b) or necessary changes to meet conditions of zoning or land development requirements made necessary by actual field conditions at the time of development;
2. A sidewalk connection, labelled as “proposed 5’ sidewalk to Georgetown Shopping Center” on “Exhibit A”, shall be provided and maintained.
3. An easement for future east-west connectivity shall be provided along the western property line.

ATTACHMENTS

- Exhibit A: Site Plan, prepared by Paradigm Engineering Services, Inc. and dated July 21, 2023
- Exhibit B: Elevations and Renderings, submitted July 27, 2023
- Exhibit C: Landscape Plan, prepared by Brunson & Company, and dated July 21, 2023
- RZ 23-01 & SLUP 23-01 Application

**STATE OF GEORGIA
CITY OF DUNWOODY**

ORDINANCE 2023-__-__

AN ORDINANCE TO AMEND THE CITY OF DUNWOODY ZONING CLASSIFICATION AND MAP FOR ZONING CONDITIONS OF LOT PARCEL NUMBER 18 345 03 017 IN CONSIDERATION OF ZONING CASE RZ 23-01 (4470 CHAMBLEE DUNWOODY ROAD) FROM O-I (OFFICE-INSTITUTION) DISTRICT ZONING CLASSIFICATION TO O-D (OFFICE-DISTRIBUTION) DISTRICT.

WHEREAS: Coro Realty Advisors seek a rezoning from the O-I (Office-Institution) District to the O-D (Office-Distribution) District, in order to develop a self-storage facility; and

WHEREAS: The Property consists of Tax Parcel 18 345 03 017, which is a landlocked parcel to the rear of the Georgetown Shopping Center, and containing a total of 3.65 acres of land that is currently zoned O-I (Office-Institution); and

WHEREAS: The proposed development would result in a 4-story self-storage facility; and

WHEREAS: The Mayor and City Council find that the proposed use aligns with the Georgetown Character Area of the Dunwoody Comprehensive Plan, which indicates that there should be limited impacts from commercial development on residential neighborhoods, less surface parking, and high quality design; and

WHEREAS: A public hearing was held by the Mayor and City Council of the City of Dunwoody as required by the Zoning Procedures Act.

NOW THEREFORE, The Mayor and City Council of the City of Dunwoody hereby **ORDAIN AND APPROVE** the rezoning of said property from the O-I (Office-Institution) District to the O-D (Office-Distribution) District subject to the following conditions:

- Exhibit A: Site Plan, prepared by Paradigm Engineering Services, Inc. and dated July 21, 2023
- Exhibit B: Elevations and Renderings, submitted July 27, 2023
- Exhibit C: Landscape Plan, prepared by Brunson & Company, and dated July 21, 2023

1. The applicant shall develop the site in general conformity with "Exhibit A", "Exhibit B", and "Exhibit C" with minor changes, and any additional changes allowed as defined by Section 27-337(b) or necessary changes to meet conditions of zoning or land development requirements made necessary by actual field conditions at the time of development;
2. A sidewalk connection, labelled as "proposed 5' sidewalk to Georgetown Shopping Center" on "Exhibit A", shall be provided and maintained.
3. An easement for future east-west connectivity shall be provided along the western property line.

**STATE OF GEORGIA
CITY OF DUNWOODY**

ORDINANCE 2023-__-__

SO ORDAINED AND EFFECTIVE this ____ day of _____ 2023.

Approved by:

Approved as to Form and Content

Lynn P. Deutsch, Mayor

City Attorney

Attest:

Sharon Lowery, City Clerk

SEAL

Exhibit B, Renderings Submitted July 27, 2023





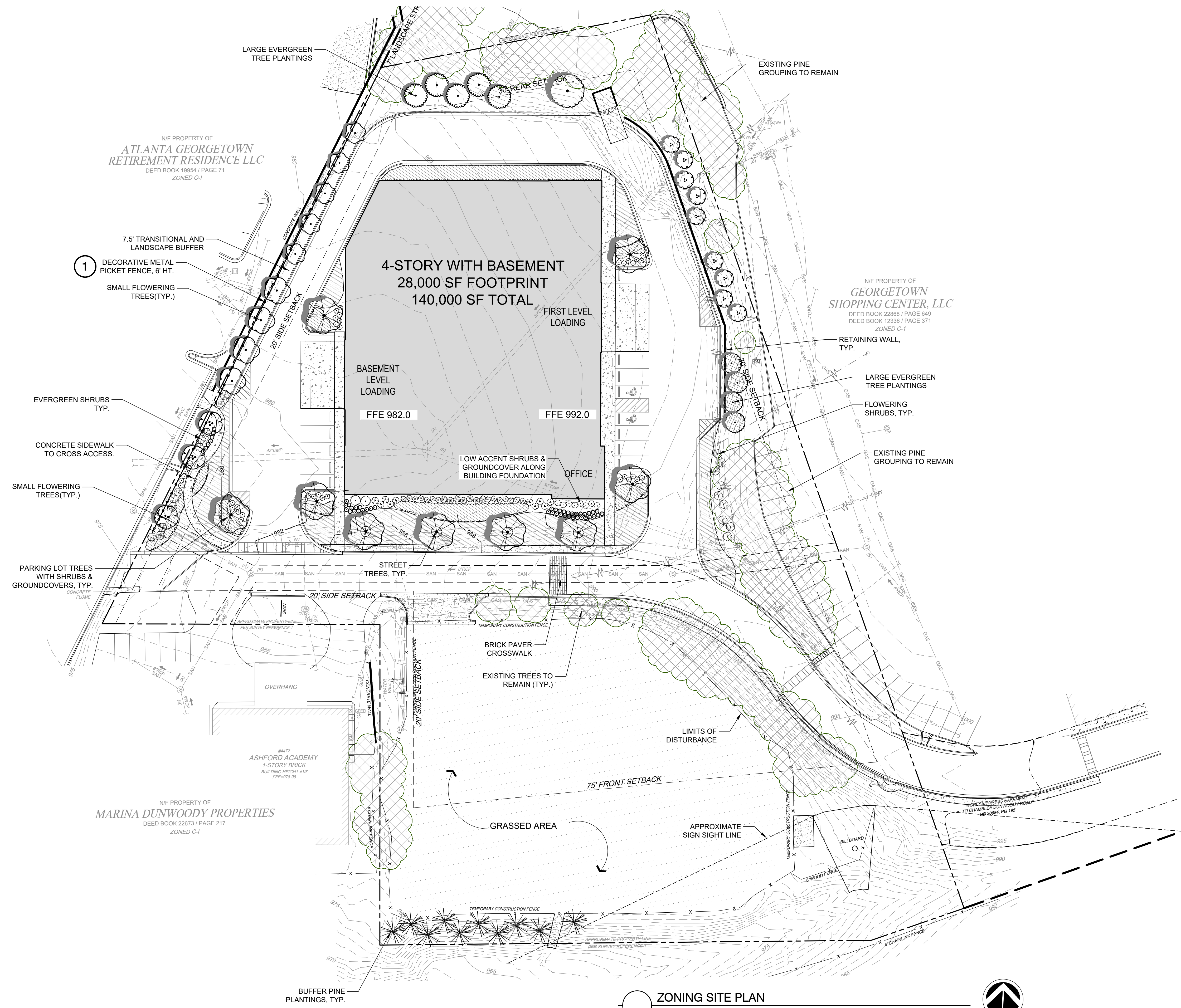

SITE SUMMARY

LOT ADDRESS:	4470 CHAMBLEE DUNWOODY ROAD
TAX PARCEL ID:	#18 346 03 017
FULL PARCEL AREA:	3.65 ACRES (159,025 SF)
EXISTING ZONING:	O-1
PROPOSED ZONING:	O-D
PROPOSED USE:	140,000 SF SELF STORAGE 4-STORIES WITH BASEMENT CLIMATE CONTROLLED BUILDING
MINIMUM LOT AREA:	43,560 SF
PROVIDED LOT AREA:	159,025 SF
MINIMUM LOT FRONTAGE:	100'
PROVIDED LOT FRONTAGE:	339' FRONTAGE ALONG I-285
MINIMUM SETBACKS:	
FRONT YARD:	75' (I-285 ROW FRONTAGE)
SIDE YARD:	20' (WITH 5' LANDSCAPE)
REAR YARD:	30'
MAXIMUM LOT COVERAGE:	80% (127,220 SF)
PROVIDED LOT COVERAGE:	72% (113,705 SF)
MAXIMUM BUILDING HEIGHT:	2-STORIES / 35'
PROPOSED BUILDING HEIGHT:	4-STORIES WITH BASEMENT / 61' (REQUIRES SPECIAL LAND USE APPROVAL)
MINIMUM OFF-STREET LOADING:	2 SPACES (12'x55')
PROVIDED OFF-STREET LOADING:	2 SPACES

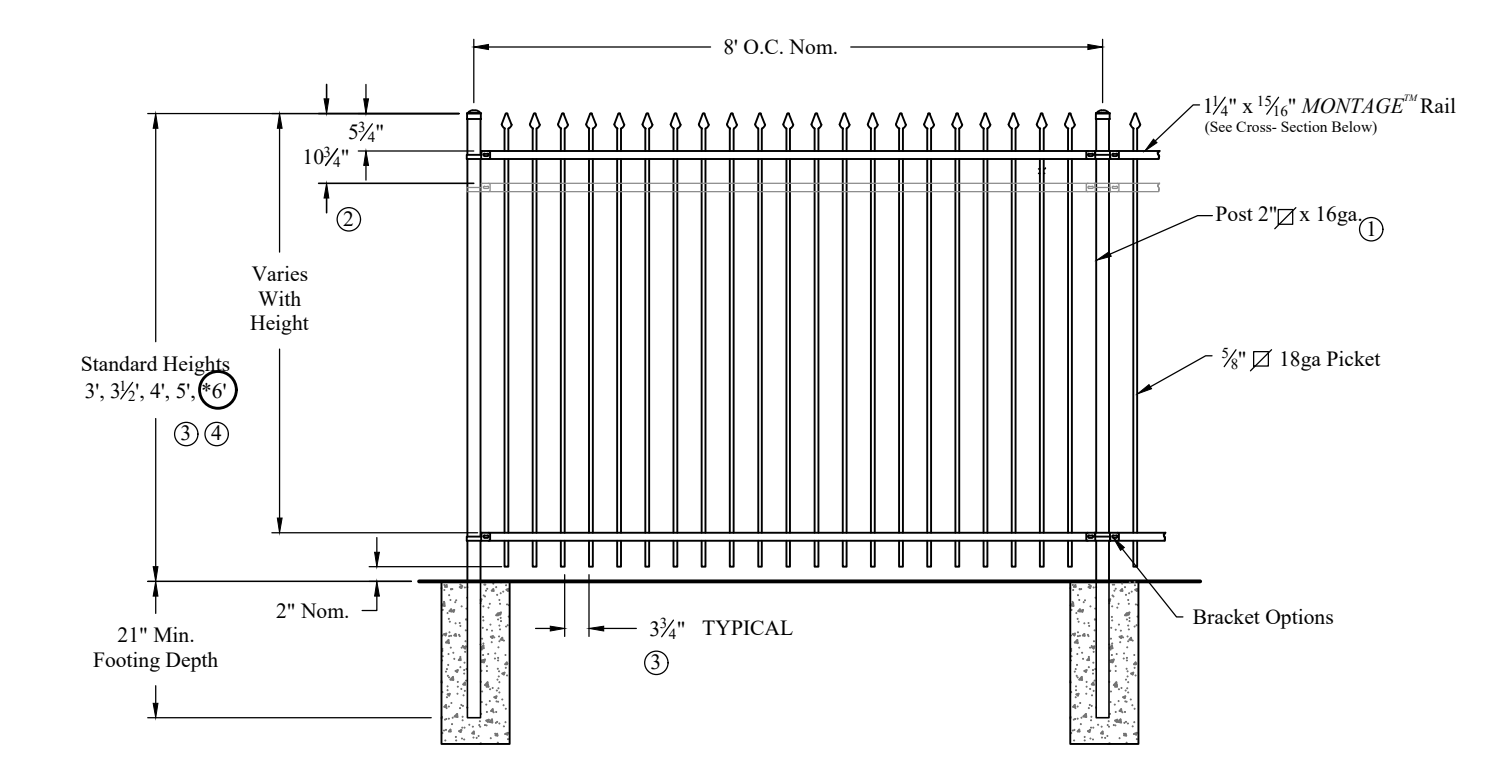

1 DECORATIVE METAL FENCE DETAIL
NTS
DETAIL-FILE

ZONING SITE PLAN
SCALE: 1" = 30'



2023, BRUNSON & COMPANY, LLC. All Rights Reserved. This document is protected by copyright and may only be utilized under express written permission by BRUNSON & COMPANY, LLC.

First Amended Amendment Application

4800 Ashford Dunwoody Road
 Dunwoody, GA 30338
 Phone: (678) 382-6800
 dunwoodyga.gov

The requirements of this application apply to comprehensive plan land use map amendments, zoning map amendments, zoning ordinance text amendments and major amendments to one or more conditions attached to previously approved zoning map amendments. If an applicant needs to further relax the dimensional standards of the Zoning/Land Development Ordinances for a specific property for the purpose of construction, they can request a variance to the text of the Zoning Ordinance. Such a request might seek to modify the strict terms of the height, area, placement, setback, yard, buffer, landscape strip, parking and loading or other regulations, but these applications will not occur concurrently, and the approval of one does not indemnify the approval of the other. The City Council, following recommendation by the Planning Commission, shall determine whether the proposed amendment meets the applicable requirements.

Application Requirements:

Item #	Required Item	Number of Copies
✓ 1	Amendment Application (See Page 7)	1 electronic copy
✓ 2	Property Owner(s) Notarized Certification (See Page 8)	1 electronic copy
✓ 3	Campaign Disclosure Statement (See Page 10-11)	1 electronic copy
4 N/A	Traffic Impact Study (If necessary, see Page 12)	1 electronic copy
5 N/A	Development of Regional Impact (If necessary, see Page 12)	1 electronic copy
✓ 6	Environmental Impact Report (If necessary, see Page 13)	1 electronic copy
✓ 7	Summary Report (See Page 5)	1 electronic copy
✓ 8	Site plan and elevations (See Page 5)	1 electronic copy
✓ 9	Written legal description/survey of the property (See Page 5)	1 electronic copy
10 ✓	Site photos (See Page 5)	1 electronic copy
✓ 11	Letter of Intent (See Page 5)	1 electronic copy
12 N/A	Overall Development Plan (For Planned Developments)	1 electronic copy
13	Payment	Pay with cash, check or credit card

Please submit the entirety of your application electronically, saved as a single PDF.

The deadline to be placed on the next month's Planning Commission agenda is the first Tuesday of the month by 3 PM.

Detailed Process and Instructions

Before the First Pre-Application Review Meeting

- Review the application packet.
- Consult the Dunwoody Zoning Ordinance at library.municode.com/ga/Dunwoody
- Fill out the amendment application (page 7).
- Prepare a preliminary site plan.
- Contact a Planner to schedule a Pre-Application Review Meeting. Contact information is online at dunwoodyga.gov.



Community Development

4800 Ashford Dunwoody Road | Dunwoody, GA 30338
Phone: (678) 382-6800 | Fax: (770) 396-4828

AMENDMENT APPLICATION

Applicant Information:

Company Name: Coro Realty Advisors, LLC c/o Dennis J. Webb, Jr. (Smith, Gambrell & Russell, LLP)
Contact Name: Dennis J. Webb, Jr.
Address: 1105 W. Peachtree Street NE, Suite 1000, Atlanta, GA 30309
Phone: 404-815-3620 Fax: Email: dwebb@sgrlaw.com
Pre-application conference date (required): 12/19/2022

Owner Information: [] Check here if same as applicant

Owner's Name: JHH 4470 Chamblee Dunwoody, LLC
Owner's Address: 3715 Northside Parkway, NW, Bldg. 400-100, Atlanta, GA 30327
Phone: 404-846-4032 Fax: Email: plugwig@cororealty.com

Property Information:

Property Address: 4470 Chamblee Dunwoody Road, Dunwoody, GA 30338 Parcel ID: 18 345 03 017
Current Zoning Classification: O-I (Office-Institution)
Requested Zoning Classification: O-D (Office-Distribution)

Applicant Affidavit:

I hereby certify that to the best of my knowledge, this amendment application form is correct and complete. If additional materials are determined to be necessary, I understand that I am responsible for filing additional materials as specified by the City of Dunwoody Zoning Ordinance. I certify that I, the applicant (if different), am authorized to act on the owner's behalf, pursuant to this application and associated actions.
Applicant's Name: Dennis J. Webb, Jr.
Applicant's Signature: [Signature] Date: 2/7/2023

Notary:

Sworn to and subscribed before me this 7th Day of February, 2023
Notary Public: Cathy Ellington
Signature: [Signature]
My Commission Expires: 3-13-25



SPECIAL LAND USE PERMIT APPLICATION



Community Development

4800 Ashford Dunwoody Road | Dunwoody, GA 30338
Phone: (678) 382-6800 | Fax: (770) 396-4828

Applicant Information:

Company Name:	Coro Realty Advisors, LLC c/o Dennis J. Webb, Jr. (Smith, Gambrell & Russell, LLP)		
Contact Name:	Dennis J. Webb, Jr.		
Address:	1105 W. Peachtree Street NE, Suite 1000, Atlanta, GA 30309		
Phone:	404-815-3620	Fax:	
Email:	dwebb@sgrlaw.com		
Pre-application conference date (required):	12/19/2022		

Owner Information: Check here if same as applicant

Owner's Name:	JHH 4470 Chamblee Dunwoody, LLC		
Owner's Address:	3715 Northside Parkway, NW, Bldg. 400-100, Atlanta, GA 30327		
Phone:	404-846-4032	Fax:	
Email:	plugwig@cororealty.com		

Property Information:

Property Address:	4470 Chamblee Dunwoody Road, Dunwoody, GA 30338	Parcel ID:	18 345 03 017
Current Zoning Classification:	O-I (Office-Institution)		
Requested Zoning Classification:	O-D (Office-Distribution) SLUP for height increase		

Applicant Affidavit:

I hereby certify that to the best of my knowledge, this amendment application form is correct and complete. If additional materials are determined to be necessary, I understand that I am responsible for filing additional materials as specified by the City of Dunwoody Zoning Ordinance. I certify that I, the applicant (if different), am authorized to act on the owner's behalf, pursuant to this application and associated actions.

Applicant's Name: Dennis J. Webb, Jr.

Applicant's Signature: [Signature] Date: 2/7/2023

Notary:

Sworn to and subscribed before me this 7th Day of February, 20 23

Notary Public: [Signature]

Signature: [Signature]

My Commission Expires: March 13, 2025



Property Owner's Certification



Community Development

4800 Ashford Dunwoody Road | Dunwoody, GA 30338
Phone: (678) 382-6800 | Fax: (770) 396-4828

Property Owner(s) Notarized Certification

I hereby certify that to the best of my knowledge, this amendment form is correct and complete. If additional materials are determined to be necessary, I understand that I am responsible for filing additional materials as specified by the City of Dunwoody Zoning Ordinance. I certify that the applicant(s) (if different) are authorized to act on my behalf, pursuant to this application and associated actions.

Property Owner (If Applicable):

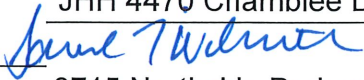
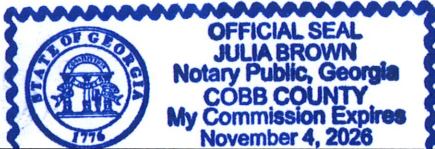
Owner Name:	JHH 4470 Chamblee Dunwoody , LLC		
Signature:		Date:	1/31/2023
Address:	3715 Northside Parkway, NW, Bldg. 400-100, Atlanta, GA 30327		
Phone:	(404) 846-4032	Fax:	
	Email: plugwig@cororealty.com		
Sworn to and subscribed before me this	31 st	Day of	January, 2023
Notary Public:			

Property Owner (If Applicable):

Owner Name:	_____		
Signature:	_____	Date:	_____
Address:	_____		
Phone:	_____	Fax:	_____
	Email: _____		
Sworn to and subscribed before me this	_____	Day of	_____, 20_____
Notary Public:	_____		

Property Owner (If Applicable):

Owner Name:	_____		
Signature:	_____	Date:	_____
Address:	_____		
Phone:	_____	Fax:	_____
	Email: _____		
Sworn to and subscribed before me this	_____	Day of	_____, 20_____
Notary Public:	_____		

Applicant's Certification



Additional Applicant Notarized Certification

Community Development
4800 Ashford Dunwoody Road | Dunwoody, GA 30338
Phone: (678) 382-6800 | Fax: (770) 396-4828

I hereby certify that to the best of my knowledge, this application form is correct and complete. If additional materials are determined to be necessary, I understand that I am responsible for filing additional materials as specified by the City of Dunwoody Zoning Ordinance. I certify that I, the applicant (if different), am authorized to act on the owner's behalf, pursuant to this application and associated actions.

Applicant:

Applicant Name: Coro Realty Advisors, LLC c/o Dennis J. Webb Jr. (Smith, Gambrell, & Russell, LLP)

Signature: *[Signature]* Date: 2/7/2023

Address: 1105 West Peachtree Street NE, Suite 1000, Atlanta, GA 30309

Phone: 404-846-4032 Fax: _____ Email: dwebb@sgrlaw.com

Sworn to and subscribed before me this 7th Day of February, 2023

Notary Public: *[Signature]*



Applicant:

Applicant Name: _____

Signature: _____ Date: _____

Address: _____

Phone: _____ Fax: _____ Email: _____

Sworn to and subscribed before me this _____ Day of _____, 20_____

Notary Public: _____

Applicant:

Applicant Name: _____

Signature: _____ Date: _____

Address: _____

Phone: _____ Fax: _____ Email: _____

Sworn to and subscribed before me this _____ Day of _____, 20_____

Notary Public: _____

Disclosures



Campaign Disclosure Statement

Community Development

4800 Ashford Dunwoody Road | Dunwoody, GA 30338
Phone: (678) 382-6800 | Fax: (770) 396-4828

Have you, within the two years immediately preceding the filing of this application, made campaign contributions aggregating \$250.00 or more to a member of the City of Dunwoody City Council or a member of the City of Dunwoody Planning Commission?

YES NO

Applicant / Owner: JHH 4470 Chamblee Dunwoody , LLC

Signature: <u><i>James T. Williams</i></u>	Date: <u>1/31/23</u>
Address: 3715 Northside Parkway, NW, Bldg. 400-100, Atlanta, GA 30327	

If the answer above is yes, please complete the following section:

Date	Government Official	Official Position	Description	Amount



Campaign Disclosure Statement

Community Development

4800 Ashford Dunwoody Road | Dunwoody, GA 30338
Phone: (678) 382-6800 | Fax: (770) 396-4828

Have you, within the two years immediately preceding the filing of this application, made campaign contributions aggregating \$250.00 or more to a member of the City of Dunwoody City Council or a member of the City of Dunwoody Planning Commission?

YES NO

Applicant / Owner: Coro Realty Advisors, LLC

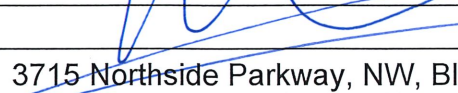
Signature: 	Date: <u>1/31/23</u>
Address: <u>3715 Northside Parkway, NW, Bldg. 400-100, Atlanta, GA 30327</u>	

If the answer above is yes, please complete the following section:

Date	Government Official	Official Position	Description	Amount

Campaign Disclosure Statement

Community Development
 4800 Ashford Dunwoody Road | Dunwoody, GA 30338
 Phone: (678) 382-6800 | Fax: (770) 396-4828

Have you, within the two years immediately preceding the filing of this application, made campaign contributions aggregating \$250.00 or more to a member of the City of Dunwoody City Council or a member of the City of Dunwoody Planning Commission? YES NO

Applicant / Owner: Dennis J. Webb, Jr. (Smith, Gambrell & Russell, LLP)

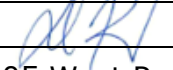
Signature: 	Date: <u>2/2/2023</u>
Address: 1105 West Peachtree Street NE, Suite 1000, Atlanta, GA 30309	

If the answer above is yes, please complete the following section:

Date	Government Official	Official Position	Description	Amount

Campaign Disclosure Statement

Community Development
 4800 Ashford Dunwoody Road | Dunwoody, GA 30338
 Phone: (678) 382-6800 | Fax: (770) 396-4828

Have you, within the two years immediately preceding the filing of this application, made campaign contributions aggregating \$250.00 or more to a member of the City of Dunwoody City Council or a member of the City of Dunwoody Planning Commission? YES NO

Applicant / Owner: J. Alexander Brock (Smith, Gambrell & Russell, LLP)

Signature: 	Date: <u>2/2/2023</u>
Address: 1105 West Peachtree Street NE, Suite 1000, Atlanta, GA 30309	

If the answer above is yes, please complete the following section:

Date	Government Official	Official Position	Description	Amount

Campaign Disclosure Statement

Community Development
 4800 Ashford Dunwoody Road | Dunwoody, GA 30338
 Phone: (678) 382-6800 | Fax: (770) 396-4828

Have you, within the two years immediately preceding the filing of this application, made campaign contributions aggregating \$250.00 or more to a member of the City of Dunwoody City Council or a member of the City of Dunwoody Planning Commission? YES NO

Applicant / Owner: Kathryn M. Zickert (Smith, Gambrell & Russell, LLP)

Signature: <u>Kathryn M Zickert</u>	Date: <u>2/2/2023</u>
Address: 1105 West Peachtree Street NE, Suite 1000, Atlanta, GA 30309	

If the answer above is yes, please complete the following section:

Date	Government Official	Official Position	Description	Amount

Environmental Site Analysis

MEMORANDUM

TO: City of Dunwoody, Community Development

FROM: J. Alexander Brock, P.E. Smith, Gambrell & Russell, LLP (GA P.E. 031209)
 Dennis J. Webb, Jr., Smith, Gambrell & Russell, LLP
 Kathryn M. Zickert, Smith, Gambrell & Russell, LLP

DATE: February 7, 2023

RE: Environmental Site Analysis – 4470 Chamblee Dunwoody Road

1) CONFORMANCE WITH THE COMPREHENSIVE PLAN.

The proposed development is in conformance with the Comprehensive Land Use Plan (“Comp Plan”). The Comp Plan’s Future Land Use Map designates the Subject Property as “Commercial (Georgetown Character Area),” a classification that supports the zoning district requested. *Dunwoody Next at 35; 37.* The “Commercial” land use category specifically lists O-D as an allowed zoning district. *Dunwoody Next at 35.* Further, the proposed development will implement certain goals and policies that are embodied in the text of the Comp Plan, including:

- (a) Redeveloping target areas, like the Georgetown Character Area. *Dunwoody Next at 11;*
- (b) Promoting the conversion of surface parking to other land uses. *Dunwoody Next at 15;*
- (c) Encouraging new commercial development in the Georgetown Character Area. *Dunwoody Next at 27;*
- (d) Promoting high quality design throughout the City. *Dunwoody Next at 15;*
- (e) Providing services and facilities to support residential neighborhoods and developments. *Dunwoody Next at 10;* and
- (f) Fostering a business friendly climate. *Dunwoody Next at 10.*

2) ENVIRONMENTAL IMPACTS OF THE PROPOSED PROJECT.

a) Wetlands

There are no wetlands on or adjacent to the Subject Property as indicated by the U. S. Fish and Wildlife Service, National Wetlands Inventory Maps. The Proposed Development will have no impacts to any wetlands.

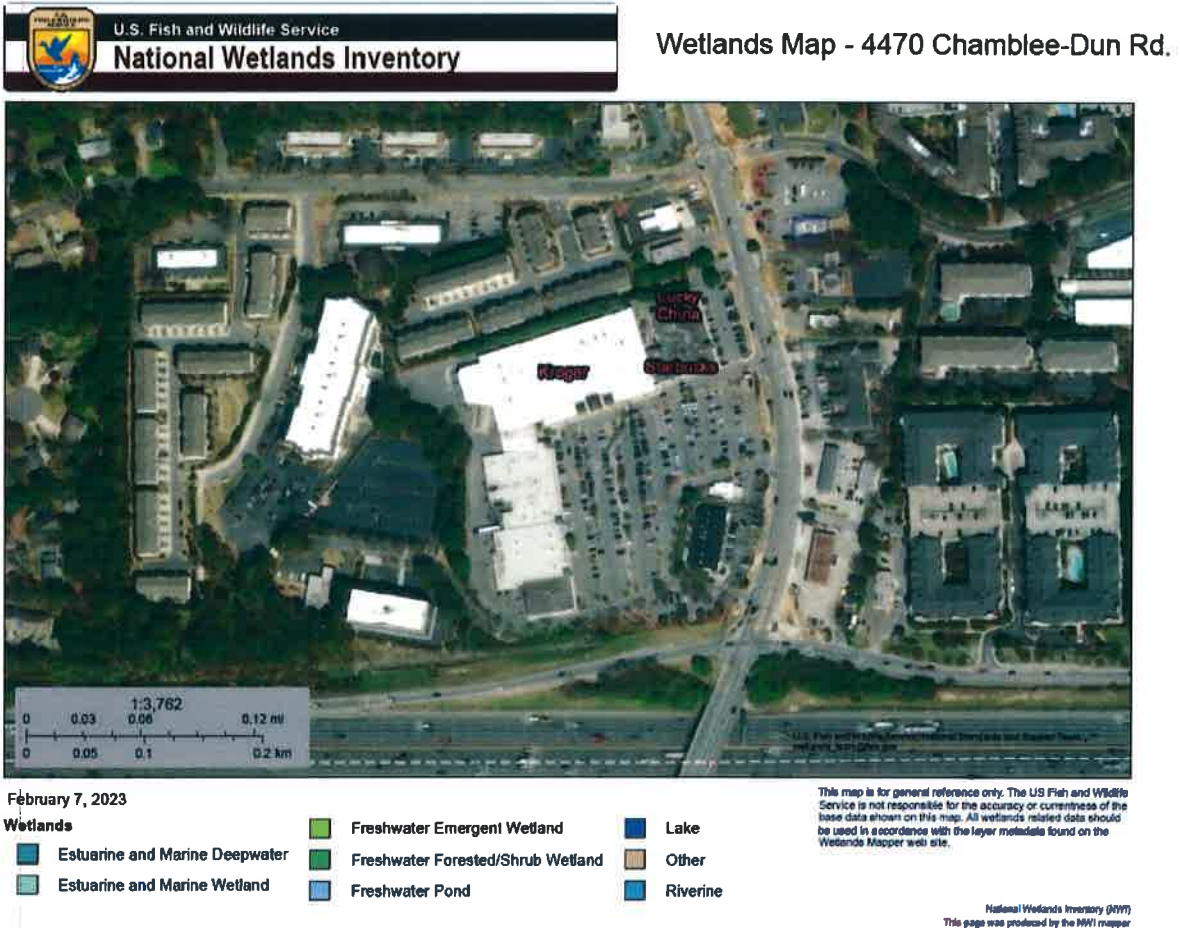

Figure 2. National Wetlands Inventory Map

b) Floodplain

No portion of the Subject Property lies within or adjacent to the floodplain as designated on the FEMA FIRM Map, Panel number 13089C0012K, effective August 15, 2019. The Proposed Development will not encroach into any portion of a floodplain.

National Flood Hazard Layer FIRMette



Legend

SEE FIRM REPORT FOR DETAILED LEGEND AND INDEX MAP FOR FIRM PANEL LAYOUT

SPECIAL FLOOD HAZARD AREAS

- Without Base Flood Elevation (BFE) Zone A, V, AE
- With BFE or Depth Zone AE, AH, VE, AR
- Regulatory Floodway
- 0.2% Annual Chance Flood Hazard: Areas of 1% annual chance flood with average depth less than one foot or with drainage areas of less than one square mile Zone X
- Future Conditions 1% Annual Chance Flood Hazard Zone X
- Area with Reduced Flood Risk due to Levee: See Notes Zone B
- Area with Flood Risk due to Levee Zone B

OTHER AREAS OF FLOOD HAZARD

- NO SCREEN Area of Minimal Flood Hazard Zone 1
- Effective LOMHs
- Area of Undetermined Flood Hazard Zone 2

OTHER AREAS

- Channel, Culvert, or Storm Sewer
- Levee, Dike, or Floodwall

GENERAL STRUCTURES

- Cross Sections with 1% Annual Chance
- Water Surface Elevation
- Coastal Transect
- Base Flood Elevation Line (BFE)
- Limit of Study
- Jurisdiction Boundary
- Coastal Transect Baseline
- Profile Baseline
- Hydrographic Features

OTHER FEATURES

- Digital Data Available
- No Digital Data Available
- Unmapped

MAP PANELS

- The pin displayed on the map is an approximate point selected by the user and does not represent an authoritative property location.

This map complies with FEMA's standards for the use of digital flood maps if it is not void as described below. The base map shown complies with FEMA's basemap accuracy standards.

The flood hazard information is derived directly from the authoritative NFHL web services provided by FEMA. This map was exported on 2/7/2023 at 10:44 AM and does not reflect changes or amendments subsequent to this date and time. The NFHL and effective information may change or become superseded by new data over time.

This map image is void if the one or more of the following map elements do not appear: basemap imagery, flood zone labels, legend, scale bar, map creation date, community identifiers, FIRM panel number, and FIRM effective date. Map images for unmapped and unmodernized areas cannot be used for regulatory purposes.

Figure 3. FEMA FIRM Panel

c) Streams/stream buffers

There are no state waters present on the Subject Property based on site observations and as reflected in the ALTA survey prepared by Metro Engineering & Surveying Co., Inc., dated December 2, 2022.

d) Slopes exceeding 25 percent over a 10-foot rise in elevation

Based on topographic maps and site observation there are existing slopes in excess of 25% over a 10-feet in rise on the Subject Property. These slopes are located along the property's eastern border and northeast corner. These slopes are anticipated to be regraded for the proposed development. The applicant will ensure proper erosion control best management practices are installed during the grading phase of the development and that the proposed grades will be properly designed to permanently stabilize any steep slopes post-development.

e) Vegetation

The project site currently developed and the remaining vegetation consists primarily of well-maintained landscaping. An IPaC Trust Resource Report was generated from the U.S. Fish and Wildlife Service. The report revealed that there is one plant native to the region that is endangered (Michaux's Sumac). This species was not found during the site visit conducted on February 7, 2023.

f) Wildlife Species (including fish)

An IPaC Trust Resource Report was generated from the U.S. Fish and Wildlife Service. The report revealed that there is one animal (Monarch Butterfly) and one plant (Michaux's Sumac) native to the region that is endangered. None were found to be present or nesting at the project location during the site visit on February 7, 2023.

g) Archeological/Historical Sites

According Georgia's Natural, Archaeological and Historic Resources GIS (GNAHRGIS) maps, the project site is not on a historic or archaeological registry. The site is currently developed with a parking lot for an adjacent office building.

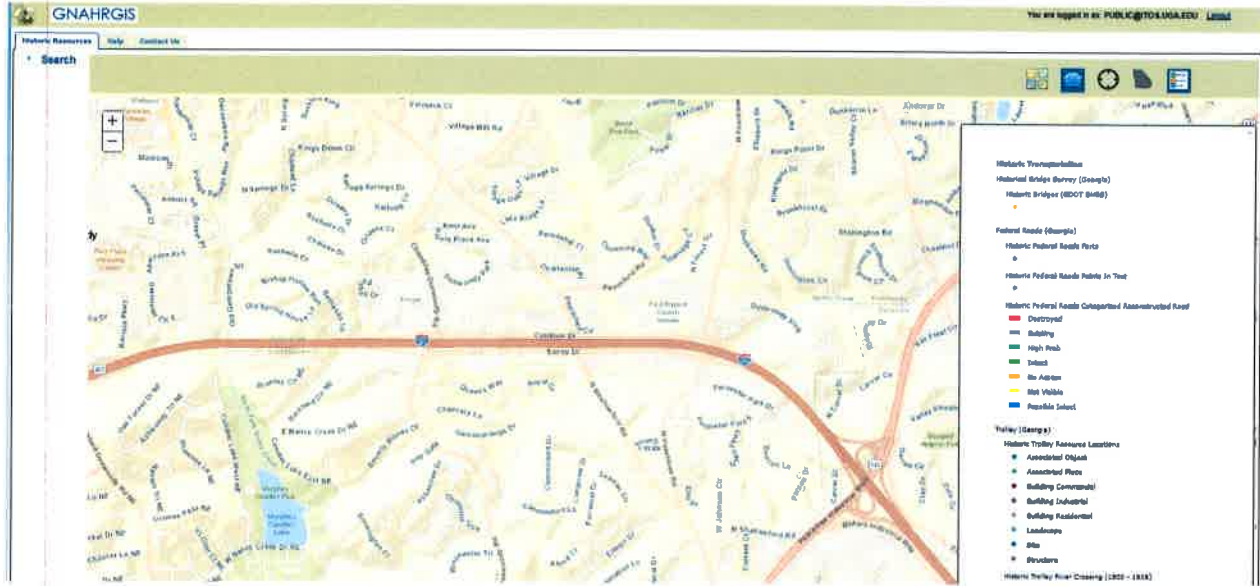

Figure 4. GNAHRGIS Map

3) **PROJECT IMPLEMENTATION MEASURES.**

a) **Protection of environmentally sensitive areas, i.e., floodplain, slopes exceeding 25 percent, river corridors.**

There are environmentally sensitive areas identified along the Subject Property's eastern and northeastern border. The environmentally sensitive areas consist of slopes exceeding 25 percent. These areas will re-graded during construction and stabilized in the post-development condition.

b) **Protection of water quality**

The Proposed Development will treat stormwater for pollutants prior to discharge from the site. The overall impact to the downstream stormwater infrastructure will be positive and an improvement over existing conditions.

c) **Minimization of negative impacts on existing infrastructure**

The Proposed Development has access to existing utilities with sufficient capacity to support the proposed use. The proposed use is not anticipated to overly burden existing utilities.

d) **Minimization on archeological/historically significant areas**

No archeological/historically significant areas were identified on or adjacent to the site and as a result no impacts are anticipated.

e) **Minimization of negative impacts on environmentally stressed communities where environmentally stressed communities are defined as communities exposed to a minimum of two environmentally adverse conditions resulting from public and private municipal (e.g., solid waste and wastewater treatment facilities, utilities, airports, and railroads) and industrial (e.g., landfills, quarries and manufacturing facilities) uses.**

There are no environmentally adverse conditions (waste treatment facilities, airports, landfills, etc.) and therefore, the Subject Property is not in an environmentally stressed area.

f) **Creation and preservation of green space and open space**

The proposed development will incorporate portions of the overall site for open space areas.

g) **Protection of citizens from the negative impacts of noise and lighting**

The Proposed Development will not have negative impacts on the surrounding uses. The proposed design, however, is incorporating the use of certain setbacks and buffers along the property lines which will minimize noise and lighting impacts to/from nearby properties along the other property lines.

h) Protection of parks and recreational green space

No existing parks will be impacted.

i) Minimization of impacts to wildlife habitats

No sensitive wildlife areas were observed during the February 7, 2023 site visit and as a result no impacts are anticipated.

Community Meeting Summary

Summary of January 26, 2022 Community Meeting

On January 26, 2022, Coro Realty Advisors, LLC (“Coro”) hosted a community meeting. Coro walked the participants through the survey, site plan, and elevations and discussed its history with the property and Georgetown Shopping Center. The primary issues raised were as follows:

1. Could the Applicant look into adding trees along the western boundary? The Applicant agreed to look into it.
2. One participant asked for a pedestrian pathway from the western side of the site to Georgetown Shopping Center. The Applicant responded that it had no control over access from the Dunwoody Pines site but was not opposed to the idea.
3. One participant asked about adding a public green to the property.
4. One participant was concerned about noise from air units. We discussed the fact that any new construction would have air units.
5. One participant asked about the loading spaces. We described their intent and the code requirement for loading spaces.

Community Meeting Sign-In

CORO Realty Advisors, LLC - Community Meeting - 4470 Chamblee Dunwoody Road,
Dunwoody, GA. January 26, 2023 - 7:00PM

Name and Address	Email Address	Phone number
Warren Strietzel 1672 Foxhall Dr.	wstrietzel@ cemccast.net	(4) 323-1904
Adam Holland 4022 Willows Way	aholland@cororealty.com	678-215-3022
Jamie Schwartz 1010 W Peachtree St	jschwartz@cororealty.com	404-846-4007
PAUL LUDWIG 815 MARSHWEN CWS	pludwig@cororealty.com	404-846-4032
Sophie Theriot 4014 Dunwoody Trace	sophie.theriot@ icloud.com	404-617-1900
Jon JACKSON, 4150 Wisconsin Dr.	Jon.JACKSON15@ gmail.com	973-223-6019
Mark Dorrill/ 1734 Chateau Dr.	MKDorrill@aol.com	770-906-7417
Andreea Ghentii 1722 Kenesaw Walk	andreeaghentii@yahoo.com	404-514-8159

Certificate of Mailing



Name and Address of Sender
 Kylie Thomas
 Smith, Gambrell & Russell, LLP
 1105 West Peachtree Street, NE
 Suite 1000
 Atlanta, GA 30309

Check type of mail or service
 Adult Signature Required Priority Mail Express
 Adult Signature Restricted Delivery Registered Mail
 Certified Mail Return Receipt for Merchandise
 Certified Mail Restricted Delivery
 Collect on Delivery (COD) Signature Confirmation
 Insured Mail Signature Confirmation Restricted Delivery
 Priority Mail

Hasler
 01/06/2023
 US POSTAGE \$59.69⁰⁰



USPS Tracking/Article Number	Addressee (Name, Street, City, State, & ZIP Code™)	Postage	(Extra Service) Fee	Handling Charge	Actual Value if Registered	Insured Value	Due Sender if COD	ASR Fee	ASR Fee	RR Fee	RR Fee	SC Fee	SC Fee	SH Fee
1.	DORRILL MARK W 1734 CHATEAU DR DUNWOODY GA 30338	.57	.47											
2.	DUNWOODY TOWNSHIP HOMEOWNERS 11340 LAKEFIELD DR STE 250 JOHNS CREEK GA 30097	.57	.47											
3.	GEORGETOWN DUNWOODY PROPERTIES LLC 6620 MCGINNIS FERRY RD DULUTH GA 30097	.57	.47											
4.	POLK IRENE 1697 FOXHALL DR DUNWOODY GA 30338	.57	.47											
5.	KWAK TAMMY 4195 WISCONSIN DR DUNWOODY GA 30338	.57	.47											
6.	SONG XINCHENG 4134 WISCONSIN DR DUNWOODY GA 30338	.57	.47											
7.	WAN DAVID S 4162 WISCONSIN DR DUNWOODY GA 30338	.57	.47											
8.	DANIELS PHILLIP ALEXANDER 4190 WISCONSIN DR DUNWOODY GA 30338	.57	.47											

9.	EMIOMA PHILIP C 4300 WALSH DR DUNWOODY GA 30338	.57	.47																
10.	GIVENS KYLE 4332 WALSH DR DUNWOODY GA 30338	.57	.47																
11.	ANDERSON ANTHONY 1785 KENSTONE WALK ATLANTA GA 30338	.57	.47																
12.	RODRIGUEZ JUAN MIGUEL 1737 KENSTONE WALK DUNWOODY GA 30338	.57	.47																
13.	SUN PING 1705 KENSTONE WALK DUNWOODY GA 30338	.57	.47																
14.	THOMAS TARA L 1734 KENSTONE WALK DUNWOODY GA 30338	.57	.47																
15.	CHATFIELD DIANE P 1676 OLD SPRING HOUSE LN DUNWOODY GA 30338	.57	.47																
16.	SCCN INC 1745 OLD SPRING HOUSE LN # 400 ATLANTA GA 30338	.57	.47																
17.	OKORO NICHOLAS OBINNA 4187 WISCONSIN DR DUNWOODY GA 30338	.57	.47																
18.	PANGUULURI NARENDRANATH 4154 WISCONSIN DR DUNWOODY GA 30338	.57	.47																
19.	LIU YANNI 4198 WISCONSIN DR DUNWOODY GA 30338	.57	.47																

20.	SHETKAR VIKAS 1696 FOXHALL DR DUNWOODY GA 30338	.57	.47																
21.	SLOAN GREGORY SCOTT 4324 WALSH DR DUNWOODY GA 30338	.57	.47																
22.	SHANG XIAODING 1777 KENSTONE WALK DUNWOODY GA 30338	.57	.47																
23.	HUANG TERESA HSIUHWA 1745 KENSTONE WALK DUNWOODY GA 30338	.57	.47																
24.	GILES CARMENCITA 1713 KENSTONE WALK DUNWOODY GA 30338	.57	.47																
25.	SALIHU SALIHU 1742 KENSTONE WALK DUNWOODY GA 30338	.57	.47																
26.	POLIMETLA SAMUEL 4003 DUNWOODY TRC ATLANTA GA 30338	.57	.47																
27.	HILGERT JON 1757 CHATEAU DR DUNWOODY GA 30338	.57	.47																
28.	DIDOCHA KATHLEEN M 4190 DUNWOODY TER ATLANTA GA 30341	.57	.47																
29.	TEMPLEMAN ALEX P 1683 CHATEAU DR DUNWOODY GA 30338	.57	.47																
30.	SPERA ROBIN C 1635 OLD SPRING HOUSE LN DUNWOODY GA 30338	.57	.47																



31.	THOMAS MINIMOLE M 630 STERLING DR BOILING SPRINGS SC 29316	.57	.47																
32.	LUONG TIM REVOCABLE TRUST 1701 FOXHALL DR DUNWOODY GA 30338	.57	.47																
33.	WILSON CAROL 1693 FOXHALL DR DUNWOODY GA 30338	.57	.47																
34.	PATEL NIMESH 4199 WISCONSIN DR ATLANTA GA 30338	.57	.47																
35.	SAVINO CLAUDIA 5409 WEST BANK DR MARIETTA GA 30068	.57	.47																
36.	OGENE UDUNMA 4186 WISCONSIN DR DUNWOODY GA 30338	.57	.47																
37.	ROD BRENDON 4194 WISCONSIN DR DUNWOODY GA 30338	.57	.47																
38.	GUO ZICHUN 1692 FOXHALL DR DUNWOODY GA 30338	.57	.47																
39.	SWINEY DAWN 1700 FOXHALL DR ATLANTA GA 30338	.57	.47																
40.	IDA LANIER LIVING TRUST 1749 KENSTONE WALKE DUNWOODY GA 30338	.57	.47																
41.	SHRIVASTAVA VIPUL 1741 KENSTONE WALK DUNWOODY GA 30338	.57	.47																



42.	TEDDY WARREN 1709 KENSTONE WALK DUNWOODY GA 30338	.57	.47																	
43.	YIN HAIRONG 1701 KENSTONE WALK DUNWOODY GA 30338	.57	.47																	
44.	DAHM JACOB DOUGLAS 4403 CHATEAU CT DUNWOODY GA 30338	.57	.47																	
45.	CUTHBERT MARGO CORRINE 1684 OLD SPRING HOUSE LN DUNWOODY GA 30338	.57	.47																	
46.	CARMAN DONMARK 345 SPINDLE CT SANDY SPRINGS GA 30350	.57	.47																	
47.	LEFFLER ANDREW J 1681 FOXHALL DR ATLANTA GA 30338	.57	.47																	
48.	JACKSON JON 4150 WISCONSIN DR DUNWOODY GA 30338	.57	.47																	
49.	STRIETZEL WARREN 1672 FOXHALL DR DUNWOODY GA 30338	.57	.47																	
50.	YADGAROV ARKADIY 1676 FOXHALL DR DUNWOODY GA 30338	.57	.47																	
51.	JOSEPH HARLAN 1688 FOXHALL DR DUNWOODY GA 30338	.57	.47																	
52.	THERIOT SOPHIE VALERIE 4014 DUNWOODY TRC DUNWOODY GA 30338	.57	.47																	



53.	MORRIS MARC LAMARR 4018 DUNWOODY TRC DUNWOODY GA 30338	.57	.47																	#4.
54.	SUSAN OSBORNE LIVING TRUST 1721 KENSTONE WALK ATLANTA GA 30338	.57	.47																	
55.	HENDERSON AMELIA DIANE 1717 KENSTONE WALK DUNWOODY GA 30338	.57	.47																	
56.	WILLS TA RESSA 4023 DUNWOODY TRCE DUNWOODY GA 30338	.57	.47																	
57.	WANG LI JUAN 4011 DUNWOODY TRC DUNWOODY GA 30338	.57	.47																	
58.	LUCAS JOSHUA ROBERT 1694 OLD SPRING HOUSE LN DUNWOODY GA 30338	.57	.47																	
59.	POWERS MARCUS 1645 OLD SPRING HOUSE LN DUNWOODY GA 30338	.57	.47																	
60.	COHEN ANDREW 1655 OLD SPRING HOUSE LN DUNWOODY GA 30338	.57	.47																	
61.	ROBERTS JONATHAN 4328 BETHESDA TRL DUNWOODY GA 30338	.57	.47																	
62.	ALVAREZ SOFIA LAURA 4336 BETHESDA TRL DUNWOODY GA 30338	.57	.47																	
63.	GEORGETOWN SQUARE TOWNHOME 1465 NORTHSIDE DR NW STE 128 ATLANTA GA 30318	.57	.47																	



64.	STARKEY PATRICK 4137 WISCONSIN DR ATLANTA GA 30338	.57	.47																
65.	WEAVER ROBERT 1581 HUNTINGDON TRL ATLANTA GA 30350	.57	.47																
66.	PIERRE KENYA T 4158 WISCONSIN DR DUNWOODY GA 30338	.57	.47																
67.	WEINTRAUB ABBEY B 4166 WISCONSIN DR DUNWOODY GA 30338	.57	.47																
68.	GANGWAL JETAN MUKUND 4328 WALSH DR DUNWOODY GA 30338	.57	.47																
69.	HURLEY PATRICK WARREN 1789 KENSTONE WALK DUNWOODY GA 30338	.57	.47																
70.	FRANGI RONALD 2850 PLEASANT OAK DR BUFORD GA 30519	.57	.47																
71.	SHAH PARTH 1738 KENSTONE WALK DUNWOODY GA 30338	.57	.47																
72.	HU YUWEN 1746 KENSTONE WALK DUNWOODY GA 30338	.57	.47																
73.	BOGARD ZACHARY B 4007 DUNWOODY TRC DUNWOODY GA 30338	.57	.47																
74.	AN ANDREW 4320 WALSH DR ATLANTA GA 30338	.57	.47																



75.	CAMPBELL MICHAEL T 1727 CHATEAU DR DUNWOODY GA 30338	.57	.47																
76.	REED GLEN EDWARD JR 1711 CHATEAU DR DUNWOODY GA 30338	.57	.47																
77.	FARRIS JESSE 1649 BETHESDA CT DUNWOODY GA 30338	.57	.47																
78.	BUTLER SUSAN 3881 LAND O LAKES DR NE ATLANTA GA 30342	.57	.47																
79.	SHARP PAUL E 1724 CHATEAU DR DUNWOODY GA 30338	.57	.47																
80.	ROUNTREE CAROLYN LEE 1712 ROCHELLE DR DUNWOODY GA 30338	.57	.47																
81.	ATLANTA GEORGETOWN PO BOX 4549 CARLSBAD CA 92018	.57	.47																
82.	TRIPATHI RAGHVENDRA 1689 FOXHALL DR DUNWOODY GA 30338	.57	.47																
83.	DAVID DONNA M CHUKWU 1677 FOXHALL DR DUNWOODY GA 30338	.57	.47																
84.	JEFFERSON LEON 4138 WISCONSIN DR DUNWOODY GA 30338	.57	.47																
85.	GORDON LAUREN 4142 WISCONSIN DR ATLANTA GA 30338	.57	.47																

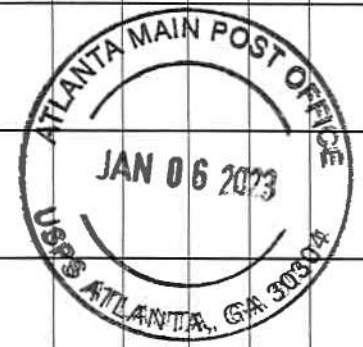

86.	BONILLA DEL ANGEL CARLOS A 1680 FOXHALL DR DUNWOODY GA 30338	.57	.47																	
87.	LU MINTAO 1684 FOXHALL DR DUNWOODY GA 30338	.57	.47																	
88.	DANNECKER KIF ROB 4010 DUNWOODY TRCE ATLANTA GA 30338	.57	.47																	
89.	HUANG CHINGWEN 4022 DUNWOODY TRC DUNWOODY GA 30338	.57	.47																	
90.	ZHU JIAQI 1725 KENSTONE WALK DUNWOODY GA 30338	.57	.47																	
91.	WANG XINGJIAN 4019 DUNWOODY TRC DUNWOODY GA 30338	.57	.47																	
92.	PS SOUTHEAST TWO LLC 701 WESTERN AVE GLENDALE CA 91201	.57	.47																	
93.	GOODE JOSPEH A 1697 CHATEAU DR DUNWOODY GA 30338	.57	.47																	
94.	WEBBER JEREMY H 1689 CHATEAU DR DUNWOODY GA 30338	.57	.47																	
95.	PB ESTATE LLC 6375 STALLION DR CUMMING GA 30040	.57	.47																	
96.	MAISURIA MAYURBHAI D 1677 OLD SPRING HOUSE LN DUNWOODY GA 30338	.57	.47																	



97.	HILDRETH STEVEN J 4312 BETHESDA TRL DUNWOODY GA 30338	.57	.47																	
98.	MERKEL ASHLEY LAUREN 4320 BETHESDA TRL DUNWOODY GA 30338	.57	.47																	
99.	KHERANI AHAD RIYAZ 4183 WISCONSIN DR ATLANTA GA 30338	.57	.47																	
100.	LIU XIAO 4149 WISCONSIN DR DUNWOODY GA 30338	.57	.47																	
101.	ARSHAD MOHAMMAD 5260 GAULEY RIVER DR STONE MOUNTAIN GA 30087	.57	.47																	
102.	ANAND PETER 4170 WISCONSIN DR DUNWOODY GA 30338	.57	.47																	
103.	BOUGHRUM LINDSAY CATHERINE 4178 WISCONSIN DR DUNWOODY GA 30338	.57	.47																	
104.	PAK KIHO 14 HIGH TOP CIR ATLANTA GA 30328	.57	.47																	
105.	PITT STEVEN F 4312 WALSH DR DUNWOODY GA 30338	.57	.47																	
106.	KAPLAN CRAIG STUART 1769 KENSTONE WALK DUNWOODY GA 30338	.57	.47																	
107.	GARTRELL TIFFANY 1761 KENSTONE WALK DUNWOODY GA 30338	.57	.47																	

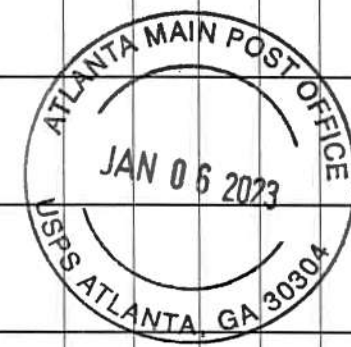

108.	CHOU JAMES S 4392 CHATEAU CT DUNWOODY GA 30338	.57	.47																	
109.	ROBINSON PAMELA R 1737 CHATEAU DR DUNWOODY GA 30338	.57	.47																	
110.	MCDONALDS USA LLC PO BOX 182571 COLUMBUS OH 43218	.57	.47																	
111.	SWANSON CHRISTOPHER WALTER 1668 OLD SPRING HOUSE LN DUNWOODY GA 30338	.57	.47																	
112.	VAUGHN DAWN 4307 OLD SPRING HOUSE CT DUNWOODY GA 30338	.57	.47																	
113.	GUMBRILL PATRICIA 1656 BETHESDA CT DUNWOODY GA 30338	.57	.47																	
114.	REMIGAILO RICHARD V JR 1657 BETHESDA CT DUNWOODY GA 30338	.57	.47																	
115.	LEMPER ARIEL ABRAHAM 4179 WISCONSIN DR ATLANTA GA 30338	.57	.47																	
116.	NWANDIKE HOWARD 4145 WISCONSIN DR ATLANTA GA 30338	.57	.47																	
117.	KIM HELEN SUN 4174 WISCONSIN DR DUNWOODY GA 30338	.57	.47																	
118.	APPIAH AARON P 7091 OX BOW RD TALLAHASSEE FL 32312	.57	.47																	



119.	CHANDWADE PARITOSH KISHOR 4308 WALSH DR # 47 DUNWOODY GA 30338	.57	.47																	
120.	LEE ALEX HANVIE 4316 WALSH DR DUNWOODY GA 30338	.57	.47																	
121.	MERCHANT ARIF 1765 KENSTONE WALK DUNWOODY GA 30338	.57	.47																	
122.	PATEL PALAY 1714 KENSTONE WALK DUNWOODY GA 30338	.57	.47																	
123.	MENELAOU PANAYIOTIS 1722 KENSTONE WALK DUNWOODY GA 30338	.57	.47																	
124.	BROWN SCOTT 4395 CHATEAU CT DUNWOODY GA 30338	.57	.47																	
125.	SCHAAP THOMAS N 4400 CHATEAU CT DUNWOODY GA 30338	.57	.47																	
126.	NEWMAN MYRON M REVOCABLE TRUST 1735 BUFORD HWY STE 215-418 CUMMING GA 30041	.57	.47																	
127.	SWILLEY GROVER CURTIS JR 182 W LINDEN ST WILMORE KY 40390	.57	.47																	



Community Meeting Letter to Neighbors

1105 W. Peachtree St. NE, Suite 1000
Atlanta, Georgia 30309-3608
Tel: 404 815-3500
www.sgrlaw.com



Dennis (Den) J. Webb, Jr.
Direct Tel: 404-815-3620
Direct Fax: 404-685-6920
dwebb@sgrlaw.com

January 5, 2023

VIA CERTIFIED MAIL

Re: COMMUNITY MEETING Regarding Proposed Development at
4470 Chamblee Dunwoody Road

Dear Neighbor:

We represent Coro Realty Advisors, LLC (“Coro”). Coro plans to file an application to rezone a parcel located at 4470 Chamblee Dunwoody Road from O-I (Office-Institution) to O-D (Office-Distribution) to develop a climate-controlled, self-storage facility. We are contacting you as property owners within the immediate area to invite you to attend a community meeting to hear more about the proposed development and offer input. The meeting will be held on Thursday, January 26, 2023 at 7:00 p.m. at The DoubleTree Hotel, in the Azalea Ballroom. The DoubleTree Hotel is located at 4386 Chamblee Dunwoody Road, Atlanta, Georgia 30341.

We look forward to seeing you then.

Thank you,

A handwritten signature in blue ink, appearing to read 'D J Webb'.

Dennis (Den) J. Webb, Jr.
Representative for Coro Realty

Site Plan

Survey

Legal Description

EXHIBIT A**Legal Description of the Property**

All of that tract of land lying and being in Land Lot 345, 18th District, DeKalb County, Georgia and being more particularly described as follows:

Commencing at a concrete monument found marking the right-of-way intersection of the western right-of-way line of Chamblee-Dunwoody Road (public right-of-way varies) with the northern right-of-way line of Interstate 285 (public right-of-way varies); thence southwesterly along said right-of-way line of Interstate 285 for a distance of ± 524 feet to a 1-inch crimped top pipe found and the **POINT OF BEGINNING**; thence along said right-of-way line the following courses and distances: South $80^{\circ}47'21''$ West for a distance of 58.34 feet to a 1/2-inch rebar found; North $80^{\circ}43'43''$ West for a distance of 291.21 feet to a 1/2-inch rebar found; thence leaving said right-of-way North $09^{\circ}49'47''$ East along the east line of lands now or formerly owned by Marina Dunwoody Properties LLC (Deed Book 22673 and Page 217) for a distance of 190.05 feet to a 1/2-inch rebar found; thence North $80^{\circ}01'30''$ West along the north line of said lands for a distance of 164.71 feet to a 1-inch open top pipe found; thence North $36^{\circ}26'47''$ East along the east line of lands now or formerly owned by Atlanta Georgetown Retirement Residence LLC (Deed Book 19954 and Page 71) for a distance of 369.00 feet to a 1/2-inch iron pin placed with cap; thence North $88^{\circ}45'18''$ East along the south line of lands now or formerly owned by JH Holdings LTD (Deed Book 5697 and Page 407) for a distance of 162.70 feet to a 1/2-inch iron pin placed with cap found; thence South $09^{\circ}31'21''$ East along the west line of lands now or formerly owned by Georgetown Shopping Center LLC (Deed Book 22577 and Page 799) for a distance of 561.47 feet to the **POINT OF BEGINNING** of said tract.

Said tract containing 3.79 acres or 165,257 square feet as depicted on an ALTA / ACSM Land Title Survey prepared by Metro Engineering and Surveying Company, Inc. of McDonough, Georgia, dated 5-21-152. (Job No. 13636).

LESS AND EXCEPT that portion of the property acquired in fee simple right of way by the Georgia Department of Transportation in that certain condemnation action filed on December 20, 2021 in the Superior Court of DeKalb County, Georgia, styled *Department of Transportation v. 0.151 acres of land; and certain easement rights; and certain limited access rights; and InTown Properties of Atlanta, LLC, et al.*, Civil Action File No. 21CV10809, and described as:

All that tract or parcel of land lying and being in Land Lot 345 of the 18th Land District of DeKalb County, Georgia, being more particularly described as follows:

Beginning at a point 239.36 feet left of and opposite Station 1108+62.68 on the construction centerline of I-285 CL on Georgia Highway Project No. NHS00-0001-00(758); running thence N $9^{\circ}50'50.4''$ E a distance of 3.93 feet to a point 243.23 feet left of and opposite station 1108+63.36 on said construction centerline laid out for I-285 CL; thence southeasterly 339.45 feet along the arc of a curve (said curve having a radius of 9038.50 feet and a chord distance of 339.43 feet on a bearing of S $85^{\circ}50'10.6''$ E) to the point 218.37 feet left of and opposite station 1112+01.87 on said construction centerline laid out for I-285 CL; thence N $0^{\circ}02'10.1''$ W a distance of 17.63 feet to a point 236.00 feet left of and opposite station 1112+01.87 on said construction centerline laid out for I-285 CL; thence S $9^{\circ}30'18.8''$ E a distance of 35.02 feet to a point 201.45 feet left of and opposite station 1112+07.63 on said construction centerline laid out for I-285 CL; thence S $80^{\circ}22'42.2''$ W a distance of 57.06 feet to a point 191.95 feet left of and opposite station 1111+51.37 on said construction centerline laid out for I-285 CL; thence N $80^{\circ}42'39.1''$ W a distance of 292.55 feet back to the point of beginning. **Containing 0.151 acres more or less.**

TOGETHER WITH said tract herein above described a non-exclusive easement for vehicular and pedestrian ingress and egress described as:

All of that tract of land lying and being in Land Lot 345, 18th District, DeKalb County, Georgia and being more particularly described as follows:

Commencing at a concrete monument found marking the right-of-way intersection of the western right-of-way line of Chamblee-Dunwoody Road (public right-of-way varies) with the northern right-of-way line of Interstate 285 (public right-of-way varies); thence northeasterly along said right-of-way line of Chamblee-Dunwoody Road North $46^{\circ}00'44''$ East for a distance of 41.47 feet to a point on the south side of an Ingress and Egress Easement and the **POINT OF BEGINNING**; thence along the south side of said Ingress and Egress Easement the following courses and distances: North $80^{\circ}15'52''$ West for a distance of 112.54 feet; thence South $65^{\circ}23'08''$ West for a distance of 75.70 feet; southwesterly 156.50 feet along the arc of a curve, concave to the northeast, having a central angle of $20^{\circ}05'52''$, a radius of 446.16 feet, and a chord bearing and distance of

South $71^{\circ}39'08''$ West for a distance of 155.70 feet; South $81^{\circ}32'08''$ West for a distance of 147.30 feet; northwest 81.12 feet along the arc of a curve, concaved to the north, having a central angle of $27^{\circ}25'14''$, a radius of 169.50 feet, and a chord bearing and distance of North $85^{\circ}16'52''$ West for a distance of 80.35 feet; North $09^{\circ}31'21''$ West for a distance of 70.43 feet; thence South $67^{\circ}22'52''$ East a distance of 24.97 feet; east 59.40 feet along the arc of a curve, concave to the north, having a central angle of $31^{\circ}05'00''$, a radius of 109.50 feet, and a chord bearing and distance of South $82^{\circ}55'22''$ East for a distance of 58.68 feet; North $81^{\circ}32'09''$ East for a distance of 149.08 feet; northeast 135.72 feet along the arc of a curve, concave to the northwest, having a central angle of $19^{\circ}50'00''$, a radius of 392.07 feet, and a chord bearing and distance of North $71^{\circ}42'25''$ East for a distance of 135.04 feet; North $65^{\circ}23'08''$ East for a distance of 98.20 feet; South $80^{\circ}15'52''$ East for a distance of 175.00 feet to a point on the western right-of-way line of Chamblee-Dunwoody Road; thence along said right-of-way line South $46^{\circ}08'20''$ West for a distance of 74.58 feet to the **POINT OF BEGINNING**.

Site Photos









Proposed Elevations





Georgetown Storage

Georgetown Storage

OFFICE

Rezoning Letter of Intent

FIRST AMENDED STATEMENT OF INTENT

and

Other Material Required by
City of Dunwoody Zoning Ordinance
for the
Rezoning Application

of

JHH 4470 Chamblee Dunwoody, LLC

**By
CORO REALTY ADVISORS, LLC**

for

± 3.79 Acres of Land
located in
Land Lot 346, 18th District, DeKalb County, City of Dunwoody
4470 Chamblee Dunwoody Road

O-I to O-D

Submitted for Applicant by:

Dennis J. Webb, Jr.
Kathryn M. Zickert
J. Alexander Brock
Smith, Gambrell & Russell, LLP
1105 W. Peachtree Street, NE
Suite 1000
Atlanta, Georgia 30309
404-815-3500

I. INTRODUCTION

This Application seeks a rezoning for \pm 3.79 acres of land located in Land Lot 346, 18th District of DeKalb County (the “Subject Property”). The Applicant asks to rezone the Subject Property from O-I (Office-Institutional) to O-D (Office-Distribution) to allow for a climate-controlled, self-storage building. The Subject Property is designated as “Commercial (Georgetown Character Area)” on the City’s Future Land Use Map (“FLUM”), a designation that supports the zoning district proposed. *Dunwoody Next*, p. 37.

The Subject Property currently houses a five-story, \pm 64,000 square foot office building and a large parking field. The five-story office building was acquired through eminent domain and is being demolished to allow for the Interstate 285 managed lane expansion. The Subject Property is directly behind and west of the Georgetown Shopping Center, a development that the Applicant owns and operates. The Subject Property can only be accessed through a private driveway that runs roughly west to east through the Applicant’s shopping center to Chamblee Dunwoody Road.

The building that the Applicant proposes will be a 4/5 split, with four stories at grade and a basement below. Each level will have a 28,000 square foot footprint and be accessed by an elevator. The building will contain an office at the first level and roughly 800 storage units ranging in size from 25 to 300 square feet. Loading will occur at one of two bays, one at the first level and one at the basement level. Office hours will be from 9:00 am to 6:00 pm, Monday through Saturday.

***Concurrent herewith, the Applicant has filed an application for a special Land Use Permit to allow for a four-story building.**

Keyless access hours will be from 6:00 am to 10:00 pm seven days per week. The building will be closed and no customer can access it from 10:00 pm to 6:00 am. Requisite parking has been provided.

The Applicant has paid particular attention to the proposed building's architecture. The building will be four-sides brick with cementitious accents. It will include shop-front-type windows on all four levels in the southeast corner. It will provide windows above the eastern loading bay. The site also will be landscaped, all to make the Subject Property look like a modern office complex.

The Applicant submits this document as a Statement of Intent with regard to this Application, a preservation of the Applicant's constitutional right, and a Written Justification for the Application as required by the City of Dunwoody Zoning Ordinance, § 27-326 *et seq.* A Site Plan has been filed contemporaneously with the Application, along with other required materials.

II. HISTORY

The Subject Property is currently zoned O-I. The Comprehensive Land Use Plan ("Comp Plan") designates the Subject Property as "Commercial (Georgetown Character Area)," a classification that supports the zoning district requested. *Dunwoody Next at 35; 37.*

III. REZONING IMPACT ANALYSIS

A.

WHETHER THE ZONING PROPOSAL IS IN CONFORMITY WITH THE POLICY AND INTENT OF THE COMPREHENSIVE PLAN.

Yes. As noted above, the FLUM designates the Subject Property as "Commercial (Georgetown Character Area)." *Dunwoody Next at 37.* The "Commercial" land use category specifically lists O-D as an allowed zoning district. *Dunwoody Next at 35.* Further, the proposed development will implement certain goals and policies that are embodied in the text of the Comp Plan, including:

- (a) Redeveloping target areas, like the Georgetown Character Area. *Dunwoody Next at 11;*
- (b) Promoting the conversion of surface parking to other land uses. *Dunwoody Next at 15;*
- (c) Encouraging new commercial development in the Georgetown Character Area. *Dunwoody Next at 27;*
- (d) Promoting high quality design throughout the City. *Dunwoody Next at 15;*
- (e) Providing services and facilities to support residential neighborhoods and developments. *Dunwoody Next at 10;* and
- (f) Fostering a business friendly climate. *Dunwoody Next at 10.*

B.

WHETHER THE ZONING PROPOSAL WILL PERMIT A USE THAT IS SUITABLE IN VIEW OF THE USE AND DEVELOPMENT OF ADJACENT AND NEARBY PROPERTIES.

Yes. The Subject Property is next to and west of the rear of the Georgetown Shopping Center, a large commercial shopping center anchored by a Kroger Grocery Store. As noted above, the Subject Property can only be accessed via a private driveway through the Georgetown Shopping Center which the Applicant owns and operates. The subject property currently contains a five-story office building that is being demolished and next door is Ashford Academy, an educational childcare and preschool center. Further south sits I-285. To the west is Dunwoody Pines, an independent living senior community housed in a five-story building and further west the Georgetown Townhomes, a 54-unit development of three-story buildings. To the north and separated from the Subject Property by a landscaped and raised berm is Dunwoody Township, a 40-unit development consisting of three-story townhomes. Hence, the proposed development is suitable in view of the use and development of adjacent and nearby properties. The Applicant also notes that it has paid special attention to the architecture of the building

proposed to insure that the intended final appearance of this development will compare favorably to other similar projects in the community, exceeding in quality and design many of the older structures currently in need of redevelopment. Further, the Appropriate has given appropriate attention to scale, buffering, and setbacks to ensure that this project will in fact blend harmoniously with and enhance its surroundings.

C.

WHETHER THE PROPERTY TO BE AFFECTED BY THE ZONING PROPOSAL HAS A REASONABLE ECONOMIC USE AS CURRENTLY ZONED.

No. The impact of the I-285 condemnation, the change in demand for suburban office and access issues make the current O-I zoning on the Subject Property economically unfeasible. Further, and to preserve its legal and constitutional objections, the Applicant states that the Zoning Ordinance of the City of Dunwoody lacks adequate standards for the City Council to exercise its power to zone and rezone. In essence, the standards are not sufficient to contain the discretion of the City Council and to provide the Courts with a reasonable basis for judicial review. Because the stated standards (individually and collectively) are too vague and uncertain to provide reasonable guidance to the City Council, the Zoning Ordinance violates the Fifth and Fourteenth Amendments of the Constitution of the United States in matters of zoning. The Zoning Resolution also violates Article I, Section III, Paragraph 1; and Article I, Paragraphs 1 and 2 of the Constitution of State of Georgia, 1983.

The City Council is granted the power to zone pursuant to Article IX, Section II, Paragraph 4 of the Constitution of the State of Georgia, 1983. It is a power which must be fairly exercised. Based on this element of fairness, the Zoning Ordinance of the City of Dunwoody violates Article IX, Section II, Paragraph 4 of the Constitution of the State of Georgia, 1983.

The Zoning Ordinance presently in effect is contrary to the best interest of the health and welfare of the citizens of the City of Dunwoody, and constitutes an arbitrary and capricious act. As a

result, the Zoning Ordinance is in violation of Article I, Section I, Paragraphs 1 and 2 of the Constitution of the State of Georgia 1983; Article I, Section III, Paragraph 1 of the Constitution of the State of Georgia; and Article I, Section II, Paragraph 3 of the Constitution of the State of Georgia, 1983. Furthermore, the Zoning Ordinance violates the due process clause and equal protection clauses of the Fifth and Fourteenth Amendments to the Constitution of the United States of America.

In addition, the Zoning Ordinance presently in effect is unconstitutional in that it renders this property unusable and destroys its marketability. Therefore, the Zoning Ordinance constitutes a taking of applicant's property without just and adequate compensation and without due process of law in violation of the Fifth and Fourteenth Amendments to the United States Constitutional and in violation of Article I, Section I, Paragraph 1 and Article I, Section III, Paragraph 1(a) of the Constitution of Georgia.

Any limitation on the time for presentation of the issues before the City Council who have the power to zone and rezone is a violation of the guarantees of free speech under Article I, Section I, Paragraph 5 of the Constitution of the State of Georgia, 1983 and the First Amendment of the Constitution of the United States of America. Further, said limitations are in violation of the right to petition and assemble, in violation of Article I, Section I, Paragraph IX of the Constitution of Georgia, 1983 and the First Amendment of the Constitution of the United States of America as well as the due process clauses of the Constitution of Georgia, 1983 and the Constitution of the United States of America.

The Zoning Ordinance of the City of Dunwoody is unlawful, null and void in that its adoption and map adoption/maintenance did not comply with the requirements of its predecessor ordinance and/or the Zoning Procedures Law, O.C.G.A. § 36-66-1, *et seq.*

The Applicant raises the defenses of failure to exhaust administrative remedies and failure to raise legal and constitutional objections.

D.

WHETHER THE ZONING PROPOSAL WILL ADVERSELY AFFECT THE EXISTING USE OR USABILITY OF ADJACENT OR NEARBY PROPERTY.

No. See section B above. In further response, the Applicant states that conditions imposed with regard to previous and similar area rezonings have resulted in responsive changes in the development plan for the Subject Property. The Applicant also intends to engage in discussions with the Dunwoody Homeowners Association and adjacent neighbors to make sure its proposal is acceptable to the community. Consequently, appropriate conditions will be considered to eliminate any potential negative impacts from the proposed development.

The primary goal of land use planning is to eliminate or minimize the potential adverse effects of dissimilar uses of adjacent tracts of land by establishing a harmonious transition between them. The traditional method of achieving this goal is through both "off-site" and "on-site" transition. Off-site transition consists of avoiding the placement of dissimilar uses next to each other by placing uses of intermediate density between them. On-site transition, which might either supplement or replace off-site transition, consists of measures imposed on or adjacent to the more intensive use to protect neighborhoods from adverse effects. Thus, this method of land use planning includes measures such as maintenance of buffers; walls, fences or berms; lighting control; noise control; aesthetic control; limitations on building location and orientation; location of or restrictions upon accessory uses; and prohibition of certain uses or hours of use normally permitted for that district. Many, if not all, of these devices have been utilized in this application.

E.**WHETHER THERE ARE OTHER EXISTING OR CHANGING CONDITIONS AFFECTING THE USE AND DEVELOPMENT OF THE PROPERTY THAT PROVIDE SUPPORTING GROUNDS FOR EITHER APPROVAL OR DISAPPROVAL OF THE ZONING PROPOSAL.**

The five-story office building on the Smaller Tract has been condemned to allow for the expansion of I-285 and is in the process of being demolished. It is highly unlikely that it or the Subject Property would be redeveloped for office, retail or commercial uses for a number of reasons, including access. The proposed development is the highest and best use for the Subject Property and will have a low impact on traffic, the natural environment and public infrastructure and no impact on schools. The proposed height of the building is compatible with heights on adjacent and nearby properties. Further, and because of the focus on the building's architecture, the physical structure will blend harmoniously with those in the area. The zoning requested here conforms to the ideals and spirit of the City of Dunwoody's Zoning Ordinance and Comp Plan while developing a practical and useful development that will re-purpose an underutilized property into an asset for the immediate area and the city as a whole.

F.**WHETHER THE ZONING PROPOSAL WILL ADVERSELY AFFECT HISTORIC BUILDINGS, SITES, DISTRICTS, OR ARCHAEOLOGICAL RESOURCES.**

The Applicant knows of no historic buildings, sites, districts, or archaeological resources either on the Subject Property or located in the immediate vicinity that would suffer adverse impacts from the rezoning requested.

G.

WHETHER THE ZONING PROPOSAL WILL RESULT IN A USE THAT WILL OR COULD CAUSE AN EXCESSIVE OR BURDENSOME USE OF EXISTING STREETS, TRANSPORTATION FACILITIES, UTILITIES, OR SCHOOLS.

The Application, if approved, is designed so as not to affect existing transportation facilities. Access to the site will be off of Chamblee Dunwoody Road, an arterial roadway sufficient to accommodate the relatively minor number of trips this site is anticipated to generate. *The Institute of Traffic Engineers, Trip Generation Manual (9th Edition)* (the “ITE Manual”) does not address urban, vertical, climate controlled storage buildings but does address Mini-Warehouses, which have some similarities but were not the same. Nonetheless, the data for Mini-Warehouses (ITE Code 151) indicates that a Mini-Warehouse use with comparable gross square footage would generate 20 vehicle trips at the AM weekday peak hour and 37 in the PM weekday peak hour. In the Applicant’s experience, these numbers are high, particularly after building lease-up. Regardless, they are significantly lower than the site used to generate. As noted above, the Smaller Tract housed a five-story, \pm 64,000 square foot office building until recently. According to the ITE Manual (General Office Building-710), that use would generate 100 vehicle trips at the AM weekday peak hour and 96 in the PM weekday peak hour.

The proposed use will have no impact on schools.

Finally, this site is served by the R.M. Clayton sewage treatment plant. Capacity is available to service waste generated by this project. Sufficient water capacity also is available.

IV. CONCLUSION

For the foregoing reasons, the Applicant respectfully requests that the Rezoning Application at issue be approved. The Applicant also invites and welcomes any comments from Staff or other

officials of the City of Dunwoody so that such recommendations or input might be incorporated as conditions of approval of this Application.

This 7th day of March, 2023.

Respectfully submitted,



Dennis J. Webb, Jr.
Kathryn M. Zickert
J. Alexander Brock
Attorney for Applicant

Smith, Gambrell & Russell, LLP
1105 W. Peachtree Street, NE
Suite 1000
Atlanta, Georgia 30309
404-815-3500

SLUP Letter of Intent

FIRST AMENDED STATEMENT OF INTENT

and

Other Material Required by
City of Dunwoody Zoning Ordinance
For the
Special Land Use Permit Application

of

JHH 4470 Chamblee Dunwoody, LLC

**By
CORO REALTY ADVISORS, LLC**

for

±3.79 Acres of Land
located in
Land Lot 346, 18th District, DeKalb County, City of Dunwoody
4470 Chamblee Dunwoody Road
Dunwoody, Georgia 30338

Submitted for Applicant by:

Dennis J. Webb, Jr.
Kathryn M. Zickert
J. Alexander Brock
Smith, Gambrell & Russell, LLP
1105 W. Peachtree Street, NE
Suite 1000
Atlanta, Georgia 30309
404-815-3500

I. INTRODUCTION

This Application seeks a Special Land Use Permit (“SLUP”) for \pm 3.79 acres of land located in Land Lot 346, 18th District of DeKalb County (the “Subject Property”). The Applicant has filed an accompanying rezoning application asking to rezone the Subject Property from O-I (Office-Institutional) to O-D (Office-Distribution) to allow for a climate-controlled, self-storage building. The Subject Property is designated as “Commercial (Georgetown Character Area)” on the City’s Future Land Use Map (“FLUM”), a designation that supports the zoning district proposed. *Dunwoody Next*, p. 37.

The Subject Property currently houses a five-story, \pm 64,000 square foot office building and a large parking field. The five-story office building was acquired through eminent domain and is being demolished to allow for the Interstate 285 managed lane expansion. The Subject Property is directly behind and west of the Georgetown Shopping Center, a development that the Applicant owns and operates. The Subject Property can only be accessed through a private driveway that runs roughly west to east through the Applicant’s shopping center to Chamblee Dunwoody Road.

The building that the Applicant proposes will be a 4/5 split, with four stories at grade and a basement below. Each level will have a 28,000 square foot footprint and be accessed by an elevator. The building will contain an office at the first level and roughly 800 storage units ranging in size from 25 to 300 square feet. Loading will occur at one of two bays, one at the first level and one at the basement level. Office hours will be from 9:00 am to 6:00 pm, Monday through Saturday. Keyless access hours will be from 6:00 am to 10:00 pm seven days per week. The building will be closed and no customer can access it from 10:00 pm to 6:00 am. Requisite parking has been provided.

The Applicant has paid particular attention to the proposed building's architecture. The building will be four-sides brick with cementious accents. It will include shop-front-type windows on all four levels in the southeast corner. It will provide windows above the eastern loading bay. The site also will be landscaped, all to make the Subject Property look like a modern office complex.

27-73(b) of the City's Zoning Code requires a SLUP for any building in the O-D district about two stores and/or 35 feet: "Buildings" in excess [of the] stated height limits may be approved through the special land use permit proceedings of article V, division 3." The Applicant files this application to allow for a building height of four stories.

The Applicant submits this document as a Statement of Intent with regard to this Application, a preservation of the Applicant's constitutional right, and a Written Justification for the Application as required by the City of Dunwoody Zoning Ordinance, § 27-326 *et seq.* A Site Plan has been filed contemporaneously with the Application, along with other required materials.

II. IMPACT ANALYSIS

The criteria considered by the City in granting a SLUP are listed in Article V, Division 3, Section 27-359 of the Code. The requested SLUPs should be granted because all applicable criteria are met.

A.

WHETHER THE PROPOSED USE IS CONSISTENT WITH THE POLICIES OF THE COMPREHENSIVE PLAN.

Yes. As noted above, the FLUM designates the Subject Property as "Commercial (Georgetown Character Area)." Dunwoody Next at 37. The "Commercial" land use category

specifically lists O-D as an allowed zoning district. *Dunwoody Next at 35*. Further, the proposed development will implement certain goals and policies that are embodied in the text of the Comp Plan, including:

- (a) Redeveloping target areas, like the Georgetown Character Area. *Dunwoody Next at 11*;
- (b) Promoting the conversion of surface parking to other land uses. *Dunwoody Next at 15*;
- (c) Encouraging new commercial development in the Georgetown Character Area. *Dunwoody Next at 27*;
- (d) Promoting high quality design throughout the City. *Dunwoody Next at 15*;
- (e) Providing services and facilities to support residential neighborhoods and developments. *Dunwoody Next at 10*; and
- (f) Fostering a business friendly climate. *Dunwoody Next at 10*.

B.

WHETHER THE PROPOSED USE COMPLIES WITH THE REQUIREMENTS OF THIS ZONING ORDINANCE.

In addition to its SLUP request, the Applicant also seeks a rezoning of the Subject Property from O-I to O-D. The proposed site plan complies with all lot and building regulations of the O-D zoning district.

C.

WHETHER THE PROPOSED SITE PROVIDES ADEQUATE LAND AREA FOR THE PROPOSED USE, INCLUDING PROVISION OF ALL REQUIRED OPEN SPACE, OFF-STREET PARKING AND ALL OTHER APPLICABLE REQUIREMENTS OF THE SUBJECT ZONING DISTRICT.

There is more than adequate land area to accommodate the proposed use. The Subject Property is + 3.79 acres. The O-D zoning district allows for up to 80% lot coverage. The Applicant will redevelop the Subject Property and comply with the allowable lot coverage. The Applicant will also comply with all open space requirements of the Code.

D.

WHETHER THE PROPOSED USE IS COMPATIBLE WITH ADJACENT PROPERTIES AND LAND USES, INCLUDING CONSIDERATION OF:

- a. Whether the proposed use will create adverse impacts upon any adjoining land use by reason of noise, smoke, odor, dust or vibration generated by the proposed use;

No. The Subject Property is adjoined by other commercial, office use and higher-intensity residential uses and will not create any adverse impacts due to noise, smoke, odor, dust or vibration.

- b. Whether the proposed use will create adverse impacts upon any adjoining land use by reason of the hours of operation of the proposed use;

No. Hours of use will be similar to the hours of use in other existing businesses in the area.

- c. Whether the proposed use will create adverse impacts upon any adjoining land use by reason of the manner of operation of the proposed use;

No. Commercial, office, retail and higher-intensity residential uses have co-existed near the Subject Property for many years with no adverse impact on the surrounding properties.

- d. Whether the proposed use will create adverse impacts upon any adjoining land use by reason of the character of vehicles or the volume of traffic generated by the proposed use; No. The Application, if approved, is designed so as not to affect existing transportation facilities. Access to the site will be off of Chamblee Dunwoody Road, an arterial roadway sufficient to accommodate the relatively minor number of trips this site is anticipated to generate. *The Institute of Traffic Engineers, Trip Generation Manual (9th Edition)* (the “ITE Manual”) does not address urban, vertical, climate controlled storage buildings but does address Mini-Warehouses, which have some similarities but are not the same. Nonetheless, the data for Mini-Warehouses (ITE Code 151) indicates that a Mini-Warehouse use with comparable gross square footage would generate 20 vehicle trips at the AM weekday peak hour and 37 in the PM weekday peak hour. In the Applicant’s experience, these numbers are high, particularly after building lease-up. Regardless, they are significantly lower than the site used to generate. As noted above, the Larger Tract housed a five-story, \pm 64,000 square foot office building until recently. According to the ITE Manual (General Office Building-710), that use would generate would generate 100 vehicle trips at the AM weekday peak hour and 96 in the PM weekday peak hour.
- e. Whether the size, scale and massing of proposed buildings are appropriate in relation to the size of the subject property and in relation to the size, scale and massing of adjacent and nearby lots and buildings;

Yes. The size, scale and massing proposed is similar to that already in the area. The Subject Property is next to and west of the rear of the Georgetown Shopping Center, a large commercial shopping center anchored by a Kroger Grocery Store. As noted above, the Subject Property can only be accessed via a private driveway through the Georgetown Shopping Center which the Applicant owns and operates. The subject property currently

contains a five-story office building that is being demolished and next door is Ashford Academy, an educational childcare and preschool center. Further south sits I-285. To the west is Dunwoody Pines, an independent living senior community housed in a five-story building and further west the Georgetown Townhomes, a 54-unit development of three-story buildings. To the north and separated from the Subject Property by a landscaped and raised berm is Dunwoody Township, a 40-unit development consisting of three-story townhomes. Hence, the proposed development is suitable in view of the use and development of adjacent and nearby properties. The Applicant also notes that it has paid special attention to the architecture of the building proposed to insure that the intended final appearance of this development will compare favorably to other similar projects in the community, exceeding in quality and design many of the older structures currently in need of redevelopment. Further, the Applicant has given appropriate attention to scale, buffering, and setbacks to ensure that this project will in fact blend harmoniously with and enhance its surroundings.

- f. Whether the proposed plan will adversely affect historic buildings, sites, districts, or archaeological resources;

The Applicant knows of no historic buildings, sites, districts, or archaeological resources either on the Subject Property or located in the immediate vicinity that would suffer adverse impacts from the requested SLUPs.

E.

**WHETHER PUBLIC SERVICES, PUBLIC FACILITIES AND UTILITIES—
INCLUDING MOTORIZED AND NONMOTORIZED TRANSPORTATION
FACILITIES—ARE ADEQUATE TO SERVE THE PROPOSED USE.**

The proposal for the site in question will have minimal effects on city streets, infrastructure or schools. As noted above, the expected traffic generation for the proposed use is minimal, and projected to decrease when compared with traffic generated by the office use currently allowed as-of-right. There is sufficient utility, water and sewer capacity to supply this site. The proposed redevelopment will have no effect on surrounding schools.

F.

**WHETHER ADEQUATE MEANS OF INGRESS AND EGRESS ARE PROPOSED,
WITH PARTICULAR REFERENCE TO NON-MOTORIZED AND MOTORIZED
TRAFFIC SAFETY AND CONVENIENCE, TRAFFIC FLOW AND EMERGENCY
VEHICLE ACCESS.**

The proposed development will be serviced by an existing driveway on Chamblee Dunwoody Road and a private drive through property that the Applicant already owns. Ingress, egress and traffic flow for the proposed use will not be a problem.

G.

**WHETHER ADEQUATE PROVISION HAS BEEN MADE FOR REFUSE AND
SERVICE AREAS.**

Yes. See the attached site plan.

H.**WHETHER THE PROPOSED BUILDING AS A RESULT OF ITS PROPOSED HEIGHT
WILL CREATE A NEGATIVE SHADOW IMPACT ON ANY ADJOINING LOT OR
BUILDING.**

No. Taller buildings are already in proximity. For example, a five-story office building is on the Subject Property now and another five-story building (Dunwoody Pines) is immediately adjacent to the west. Further, the Applicant is meeting the setback requirements on the western property line.

III. PRESERVATION OF CONSTITUTIONAL RIGHTS

The Applicant respectfully submits that the Zoning Ordinance of the City of Dunwoody lacks adequate standards for the City Council to exercise its power to grant special land use permits. In essence, the standards are not sufficient to contain the discretion of the City Council and to provide the Courts with a reasonable basis for judicial review. Because the stated standards (individually and collectively) are too vague and uncertain to provide reasonable guidance to the City Council, the Zoning Ordinance violates the Fifth and Fourteenth Amendments of the Constitution of the United States in matters of zoning. The Zoning Resolution also violates Article I, Section III, Paragraph 1; and Article I, Paragraphs 1 and 2 of the Constitution of State of Georgia, 1983.

The City Council is granted the power to zone pursuant to Article IX, Section II, Paragraph 4 of the Constitution of the State of Georgia, 1983. It is a power which must be fairly exercised. Based on this element of fairness, the Zoning Ordinance of the City of Dunwoody violates Article IX, Section II, Paragraph 4 of the Constitution of the State of Georgia, 1983.

The Zoning Ordinance presently in effect is contrary to the best interest of the health and welfare of the citizens of the City of Dunwoody, and constitutes an arbitrary and capricious act. As a result, the Zoning Ordinance is in violation of Article I, Section I, Paragraphs 1 and 2 of the

Constitution of the State of Georgia 1983; Article I, Section III, Paragraph 1 of the Constitution of the State of Georgia; and Article I, Section II, Paragraph 3 of the Constitution of the State of Georgia, 1983. Furthermore, the Zoning Ordinance violates the due process clause and equal protection clauses of the Fifth and Fourteenth Amendments to the Constitution of the United States of America.

In addition, the Zoning Ordinance presently in effect is unconstitutional in that it renders this property unusable and destroys its marketability. Therefore, the Zoning Ordinance constitutes a taking of applicant's property without just and adequate compensation and without due process of law in violation of the Fifth and Fourteenth Amendments to the United States Constitutional and in violation of Article I, Section I, Paragraph 1 and Article I, Section III, Paragraph 1(a) of the Constitution of Georgia.

Any limitation on the time for presentation of the issues before the City Council who have the power to zone and rezone is a violation of the guarantees of free speech under Article I, Section I, Paragraph 5 of the Constitution of the State of Georgia, 1983 and the First Amendment of the Constitution of the United States of America. Further, said limitations are in violation of the right to petition and assemble, in violation of Article I, Section I, Paragraph IX of the Constitution of Georgia, 1983 and the First Amendment of the Constitution of the United States of America as well as the due process clauses of the Constitution of Georgia, 1983 and the Constitution of the United States of America.

The Zoning Ordinance of the City of Dunwoody is unlawful, null and void in that its adoption and map adoption/maintenance did not comply with the requirements of its predecessor ordinance and/or the Zoning Procedures Law, O.C.G.A. § 36-66-1, et seq.

IV. CONCLUSION

For the foregoing reasons, the Applicant respectfully requests that the SLUP at issue be approved. The Applicant also invites and welcomes any comments from Staff or other officials of the City so that such recommendations or input might be incorporated as conditions of approval of this Application.

This 7th day of March, 2023.

Respectfully submitted,



Dennis J. Webb, Jr.
Kathryn M. Zickert
J. Alexander Brock
Attorney for Applicant

Smith, Gambrell & Russell, LLP
1105 W. Peachtree Street, NE
Suite 1000
Atlanta, Georgia 30309
404-815-3500

Curb Cut Closure Letter

1105 W. Peachtree St. NE, Suite 1000
 Atlanta, Georgia 30309-3608
 Tel: 404 815-3500
 www.sgrlaw.com



Dennis (Den) J. Webb, Jr.
 Direct Tel: 404-815-3620
 Direct Fax: 404-685-6920
 dwebb@sgrlaw.com

March 3, 2023

Richard McCloud
 Community Development Director
 City of Dunwoody
 4800 Ashford Dunwoody Road
 Dunwoody, GA 30338

**Re: 4478 Chamblee Dunwoody Road: Legal Reasons Why the
 Southernmost Curb Cut Cannot be Closed**

Dear Richard:

As you know, Coro Realty Advisors, LLC (“Coro”) filed an application to rezone property (the “Zoning Application”) at 4470 Chamblee Dunwoody Road (the “Subject Property”) to the O-D (Office Distribution) district to allow for a vertical self-storage facility. During initial review, Staff indicated that it would require as a condition of the rezoning that the southernmost curb cut at Georgetown Plaza Shopping Center, which is next-door at 4478 Chamblee Dunwoody Road (“Georgetown Plaza”), be closed. As we have discussed, the Rezoning Application does not include Georgetown Plaza. The City has no authority to place a zoning condition on the Subject Property that requires action on a different property not before the City Council. Premitting this fact, however, there are two additional legal reasons why this request cannot be met. I promised to write and provide detail on them.

First, the curb cut on Chamblee Dunwoody Road and access to it are protected by a recorded easement. The owner of 4472 Chamblee Dunwoody Road is a beneficiary of the easement and has a legal, nonpossessory property right to access and use both the curb cut and the appurtenant driveway, including the

March 3, 2023

Page 2

driveway that bisects the Subject Property and the driveway through Georgetown Plaza. I attach copies of the recorded easement documents hereto.

Second, at least two tenants at Georgetown Plaza— Starbucks and Kroger— have contractual rights to the relevant curb cut and the existing driveways to it. The Starbucks lease states in relevant part:

21. PARKING AND ACCESS. At no expense to Tenant and/or its employees or customers, Landlord shall provide all non-exclusive parking for Tenant's employees and customers, as needed to meet all code and permitting requirements for Tenant's use as a coffee store. After the Commencement Date, Landlord shall not vary or permit to be varied the existing means of ingress to and egress from the Building and the Shopping Center in any manner that would affect Tenant's business operations.

Similarly, the Kroger lease states that:

3. The entire tract of land on which Landlord is to construct said Shopping Center is shown on the plot plan marked Exhibit "C-1" and attached to and made a part hereof. Such plot plan designates the location and size of all buildings to be constructed, store sizes, parking area, which shall be sufficient for 550 cars, customer parcel pickup facilities, and tenants' delivery service areas. All that portion of the tract of land not covered by buildings is to be Common Area for the joint use of all tenants, customers, invitees, and employees. No part of the Common Area may be improved with additional buildings, nor may the parking lot layout, including parking spaces, aisles, driveways, and

March 3, 2023
Page 3

walkways, be altered or removed without the prior written consent of
Tenant.

Sincerely,

A handwritten signature in blue ink, appearing to read "DJI", is positioned above the typed name.

Dennis (Den) J. Webb, Jr.

DJW/rjc

SGR/42221249.1

WARRANTY DEED

Guaranty Title Insurance Company

Atlanta, Georgia

2533 600

STATE OF MASSACHUSETTS

COUNTY OF SUFFOLK

THIS INDENTURE, made this 7th day of May in the Year of Our Lord One Thousand Nine Hundred and Seventy between

FIFTY ASSOCIATES, a Massachusetts corporation

of the State of Massachusetts and County of Suffolk, party of the first part, and

EDUCARE, INC., a corporation

of the State of and County of party of the second part.

WITNESSETH: That the said party of the first part, for and in consideration of the sum of TEN AND NO/100 (\$10.00) DOLLARS and other good and valuable consideration XXXX in hand paid, at and before the sealing and delivery of these presents, the receipt of which is hereby acknowledged, has granted, bargained, sold and conveyed, and by these presents does grant, bargain, sell and convey unto the said party of the second part, its successors

heirs and assigns, all that tract or parcel of land lying and being in DeKalb County, Georgia, to-wit:

All that tract of land lying and being in Land Lot 345 of the 18th District of DeKalb County, Georgia, and being more particularly described as follows:

TO FIND THE POINT OF BEGINNING, BEGIN at an iron pin on the northerly side of the Circumferential Highway (also known as F.A. Project No. I-285-1(17)94, which iron pin is 192.6 feet northerly from Highway Station 1111+19.2'; thence north 80 degrees 47 minutes west, 292.92 feet to an iron pin, which is the POINT OF BEGINNING. From the point of beginning thus established, running thence north 80 degrees 47 minutes west, 260.08 feet to an iron pin; thence north 36 degrees 26 minutes east, 216.16 feet to an iron pin on the southerly side of a 60-foot private drive; thence south 79 degrees 39 minutes east along the southerly side of said 60-foot private drive, 163.88 feet to an iron pin; thence south 10 degrees 01 minute west, 190 feet to the point of beginning; said tract containing 0.93126 acre and is more particularly shown on Plat of Survey prepared by Virgil F. Gaddy & Associates, dated January 17, 1968, revised June 5, 1968, revised June 28, 1968, recorded in Deed Book 2522, page 278, DeKalb County, Georgia, Records.

ALSO: The Grantor herein gives and grants to the Grantee herein the non-exclusive right to use the improved 60-foot private drive lying north of and adjacent to the lot hereby conveyed for purposes of ingress and egress to and from this lot; the Grantor reserving the right to relocate said 60-foot private drive at any time, and from time to time, so long as the relocated drive is of the same or better quality and provides similar ingress and egress to and from the lot hereby conveyed. Grantee, by acceptance hereof, covenants and agrees to pay to Grantor, Grantee's pro-rata share of costs incurred in the maintenance of said 60-foot private drive, at its present or changed location, and shall be a covenant running with the land conveyed hereby. Said payment shall be made within thirty (30) days following the completion of work for which expense is incurred. Grantee's pro-rata share of such expense shall be that portion or ratio of the expense which the number of front feet of the Grantee's property fronting on said 60-foot private drive conveyed hereby front on said 60-foot private drive bears to the total number of feet fronting on said 60-foot private drive. For example, if there should be 1800 feet fronting on such 60-foot private drive (both sides combined) Grantee's pro-rata share of such expense shall be determined by the ratio of 163.88 to 1800.

Ga. Real Property Tax \$ 30.00 Paid J. L. F. 70 [Signature] Dep. Clerk DeKalb Sup. Ct.

Burden

10

2533 601

TO HAVE AND TO HOLD the said tract or parcel of land, with all and singular the rights, members and appurtenances thereof, to the same being, belonging, or in anywise appertaining, to the only proper use, benefit and behoof of the said part Y of the second part. Its successors and assigns forever, in Fee Simple.

AND THE SAID part Y of the first part, for itself, its successors/ ~~XXXXXXXXXXXX~~ will warrant and forever defend the right and title to the above described property unto the said part Y of the second part, its successors and assigns, against the lawful claims of all persons whomsoever.

IN WITNESS WHEREOF, the said part Y of the first part has hereunto set its hand, and affixed its seal, the day and year above written.

Signed, sealed and delivered in presence of:

Unofficial Witness
Anthony J. Depina
Notary Public

FIFTY ASSOCIATES
BY: Phillip W. McGeoffrey, Jr. (Seal) President
ATTEST: George M. Lovejoy, Jr. (Seal) Treasurer & Clerk



RECORDED MAY 27 1970 [Signature] CLERK

WARRANTY DEED

FROM _____
TO _____
COUNTY _____
CLERK'S OFFICE, SUPERIOR COURT
Filed for Record at _____
Recorded in Deed Book _____
Page _____
Clerk



Guaranty Title
Insurance Company
Home Office
Atlanta, Georgia

DECLARATION OF EASEMENT

SCHAUMANN & COMPANY, a Georgia corporation, for itself, its successors and assigns, does hereby declare and publish the following perpetual easements and licenses for the purposes and uses hereinafter set forth.

Schaumann & Company is the fee simple owner of the real property described on Exhibits "A", "B", and "C", attached hereto and made a part hereof by reference. The Commonwealth Corporation, a Florida corporation, is the holder of a first lien deed to secure debt on the real property described in Exhibits "A", "B", and "C" attached hereto, and therefore joins in the execution of this declaration.

Schaumann & Company plans to construct a high rise office building upon the real property described on Exhibit "A" attached hereto and therefore desires that ingress and egress to and from the real property described on Exhibit "A" always be available from Chamblee-Dunwoody Road and that it also be possible to run various utility lines from Chamblee-Dunwoody Road to the real property described on Exhibit "A". Therefore, Schaumann & Company does hereby declare that a perpetual easement does henceforth exist over, through, upon and across that certain right of way of real property described fully on Exhibit "B" attached hereto for the purposes of egress and ingress to and from Chamblee-Dunwoody Road to the real property described on Exhibit "A", as well as the right to install and maintain all utilities within said right of way of real property described on Exhibit "B", in order that utilities may be installed and maintained from Chamblee-Dunwoody Road to the real property described on Exhibit "A".

*Appt
&
Builder
Ex B extends
onto Jely
boundary
of S.P.*

*Ramel
JMS
SJA*

20

Schaumann & Company plans to construct a drainage retention pond in the most southerly portion of the real property described on Exhibit "C" attached hereto. Schaumann & Company desires that the drainage and run-off arising from the real property described on Exhibit "A" be drained into the drainage retention pond to be constructed on the most southerly portion of the real property described on Exhibit "C".

Therefore, Schaumann & Company hereby declares a perpetual license for the drainage and run-off from the real property described on Exhibit "A" to be drained into the drainage pond to be constructed on the most southerly portion of the real property described on Exhibit "C", so long as this license does not interfere with any planned usage of improvements constructed or to be constructed on the real property described on Exhibit "C".

The easements and licenses herein declared shall bind and shall inure to the benefit of the successors in title of Schaumann & Company.

WITNESS the hands and seals of the undersigned this 31st day of January, 1974.

SCHAUMANN & COMPANY
 BY: Robert M. Schaumann
 Robert M. Schaumann, President
 ATTEST: Jo Anne Whitmire
 Jo Anne Whitmire, Secretary



As to Schaumann:
 Signed, sealed and delivered
 in the presence of:

Charles H. Bedell
 WITNESS

William J. [Signature]
 NOTARY PUBLIC
 Notary Public, Georgia, State of Largo
 My Commission Expires April 2, 1974



THE COMMONWEALTH CORPORATION

BY: *Ann H. Adams*
Its VICE PRESIDENT



ATTEST: _____
Its _____

As to Commonwealth:
Signed, sealed and
delivered in the presence of:

Merce H. Bevil
WITNESS

Marvin
NOTARY PUBLIC



Notary Public, Georgia, State at Large
My Commission Expires April 2, 1974

Theresa B. ...
Clerk

FILED & RECORDED
DEKALB CO. GA.
FEB 4 2 00 PM '74

EXHIBIT "A"

All that tract or parcel of land lying and being in Land Lot 345 of the 18th District of DeKalb County, Georgia, and being more particularly described as follows:

To find the TRUE POINT OF BEGINNING, begin at, an iron pin on the westerly land lot line of Land Lot 345 which iron pin is 933.2 feet southerly, as measured along the westerly land lot line of Land Lot 345, from the northwesterly corner of Land Lot 345; running thence south 81 degrees 3 minutes east 192.5 feet to an iron pin; running thence south 80 degrees 44 minutes east 81.3 feet to an iron pin; running thence north 36 degrees 31 minutes east 216.2 feet to an iron pin located at the TRUE POINT OF BEGINNING; running thence north 36 degrees 31 minutes east 369 feet to an iron pin; thence running north 88 degrees 49 minutes east a distance of 162.7 feet to an iron pin; thence running south 9 degrees 28 minutes east a distance of 560.9 feet to an iron pin on the northerly right-of-way line of Interstate 285; running thence south 80 degrees 33 minutes west along the northerly right-of-way line of Interstate 285 a distance of 58.2 feet to an iron pin; running thence north 80 degrees 44 minutes west a distance of 292.9 feet to an iron pin; running thence north 10 degrees 16 minutes east a distance of 190.0 feet to an iron pin; running thence north 79 degrees 58 minutes west a distance of 164.5 feet to an iron pin located at the TRUE POINT OF BEGINNING; being designated as Parcel I, containing 3.797 acres, as per survey for Schaumann and Co. by Chester M. Smith, Jr., Registered Land Surveyor, dated October 18, 1973, being revised January 7, 1974.

Subject property
4470 Chamblee
Dunwoody
Road

Ex "A" legal
is incomplete,
but clearly
intends to
describe the S.P.

Oh, sue

Rumz
Juw
DPA

EXHIBIT "B"

All that tract or parcel of land lying and being in Land Lot 345 of the 18th District of DeKalb County, Georgia, and being more particularly described as follows:

BEGINNING at a point on the northwesterly right-of-way line of Chamblee-Dunwoody Road 45.1 feet northeasterly as measured along the northwesterly right-of-way line of Chamblee-Dunwoody Road and following the curvature thereof from a point where the northwesterly right-of-way line of Chamblee-Dunwoody Road intersects the northwesterly right-of-way line of Interstate 285; thence running north 80 degrees 18 minutes west 112 feet to a point; thence running south 65 degrees 21 minutes west 75.7 feet to a point; thence running southwesterly along the arc of a curve 155.7 feet to a point (the chord of said arc being south 71 degrees 37 minutes west 154.9 feet); thence running south 81 degrees 30 minutes west 147.3 feet to a point; thence running southwesterly, westerly, and northwesterly along the arc of a curve 82.2 feet to a point (the chord of said arc being north 85 degrees 19 minutes west 81.4 feet); thence running north 9 degrees 28 minutes west 70.1 feet to a point; thence running south 67 degrees 25 minutes east 22.5 feet to a point; thence running southeasterly, easterly, and northeasterly along the arc of a curve 64.4 feet to a point (the chord of said arc being 63.6 feet south 82 degrees 57 minutes east); thence running north 81 degrees 30 minutes east 147.3 feet to a point; thence running northeasterly along the arc of a curve 135 feet to a point (the chord of said arc being north 71 degrees 37 minutes east 134.3 feet); thence running north 65 degrees 21 minutes east 98.2 feet to a point; thence running south 80 degrees 18 minutes east 175.1 feet to a point on the northwesterly right-of-way line of Chamblee-Dunwoody Road; thence running south 46 degrees 26 minutes west along the northwesterly right-of-way line of Chamblee-Dunwoody road 74.9 feet to the point of beginning; being designated as Drive Easement containing 0.837 acres as per survey for Schaumann and Co. by Chester M. Smith, Jr., Registered Land Surveyor, dated October 18, 1973, revised January 7, 1974.

Easement Area (.84 acres)

Handwritten signature/initials

EXHIBIT "C"

All that tract or parcel of land lying and being in Land Lot 345 of the 18th District of DeKalb County, Georgia, and being more particularly described as follows:

To find the TRUE POINT OF BEGINNING, begin at the intersection formed by the southerly right of way line of Old Spring House Lane (60' right of way) and the westerly right of way line of Chamblee-Dunwoody Road; thence westerly along the southerly right of way line of Old Spring House Lane and following the curvature thereof 150.43 feet to a point on the southerly right of way line of Old Spring House Lane; thence westerly along the southerly right of way line of Old Spring House Lane 756.06 feet to the center line of a 30' unnamed asphalt street; thence in a southerly direction along the center line of said 30' unnamed asphalt street and following the curvature thereof 196.00 feet to an iron pin, said iron pin being the TRUE POINT OF BEGINNING; thence running south 89°22'00" east a distance of 186.36 feet to an iron pin; thence running south 1°10'00" east a distance of 288 feet to an iron pin; thence running south 36°23'30" west a distance of 613.8 feet to an iron pin; thence running north 80°47'00" west a distance of 81.26 feet to an iron pin; thence running north 0°48'30" west a distance of 321.15 feet to an iron pin in the center line of said unnamed asphalt street; thence running northeasterly along the center line of said unnamed asphalt street and following the curvature thereof a distance of 166.97 feet to a point; thence running north 22°34'30" east along the center line of said unnamed asphalt street a distance of 50.91 feet to a point; thence running northeasterly along the center line of said unnamed asphalt street and following the curvature thereof a distance of 95.33 feet to a point; thence running north 17°55'30" east along the center line of said unnamed asphalt street a distance of 239.36 feet to the iron pin located at the TRUE POINT OF BEGINNING; containing 4.095 acres as per survey for Schaumann & Company by Joseph C. King, Registered Land Surveyor, dated December 10, 1968, revised June 24, 1972, and June 11, 1973.

Note: Chain of title shows easement rights granted to Atlanta Georgetown Retirement Residence

*Revised
JW
JW*

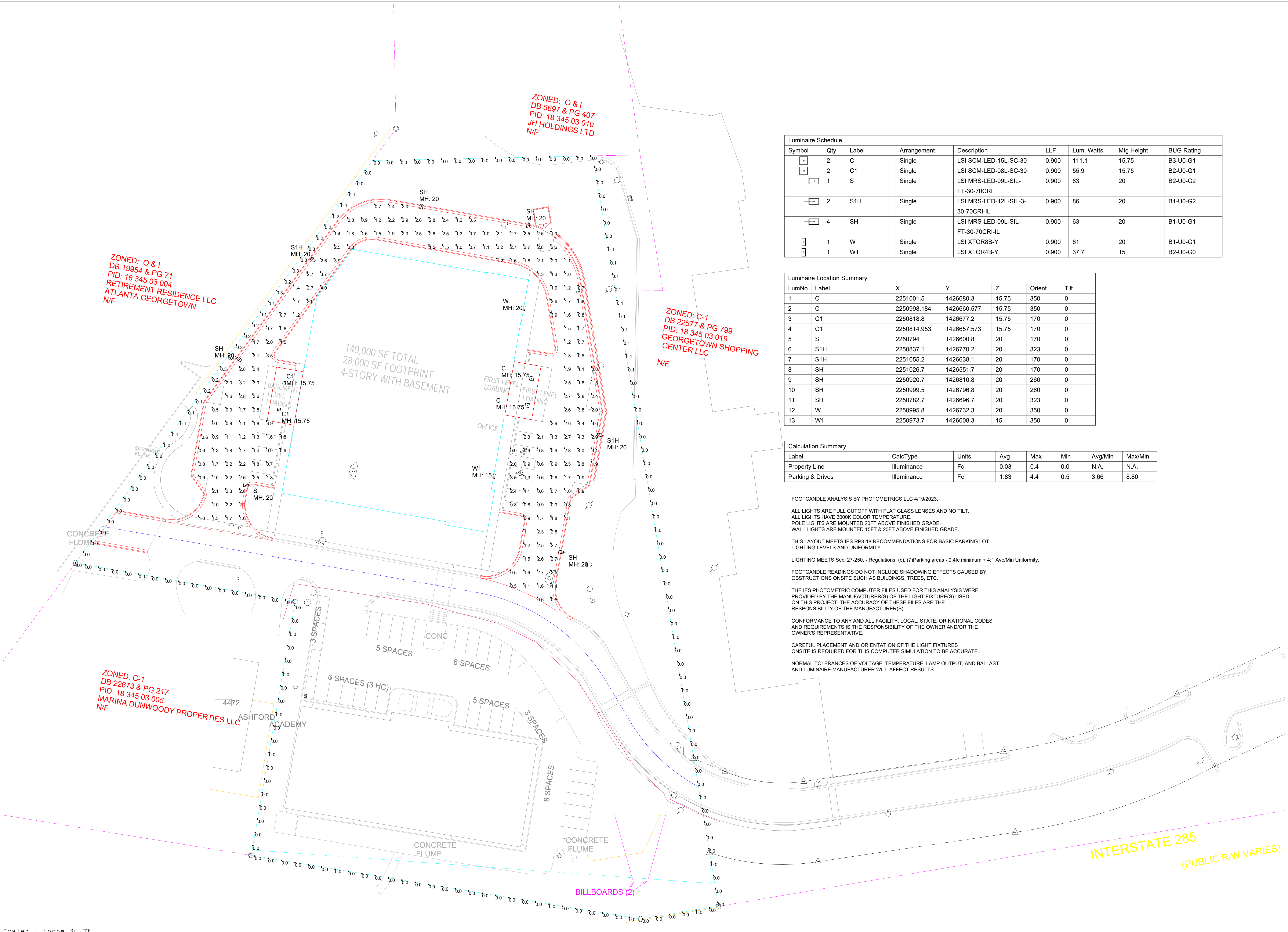

ZONED: O & I
DB 5697 & PG 407
PID: 18 345 03 010
JH HOLDINGS LTD
N/F

ZONED: O & I
DB 19954 & PG 71
PID: 18 345 03 004
RETIREMENT RESIDENCE LLC
ATLANTA GEORGETOWN
N/F

ZONED: C-1
DB 22577 & PG 799
PID: 18 345 03 019
GEORGETOWN SHOPPING
CENTER LLC
N/F

ZONED: C-1
DB 22673 & PG 217
PID: 18 345 03 005
MARINA DUNWOODY PROPERTIES LLC
N/F

Luminaire Schedule								
Symbol	Qty	Label	Arrangement	Description	LLF	Lum. Watts	Mtg Height	BUG Rating
+	2	C	Single	LSI SCM-LED-15L-SC-30	0.900	111.1	15.75	B3-U0-G1
+	2	C1	Single	LSI SCM-LED-08L-SC-30	0.900	55.9	15.75	B2-U0-G1
+	1	S	Single	LSI MRS-LED-09L-SIL-FT-30-70CRI	0.900	63	20	B2-U0-G2
+	2	S1H	Single	LSI MRS-LED-12L-SIL-30-70CRI-IL	0.900	86	20	B1-U0-G2
+	4	SH	Single	LSI MRS-LED-09L-SIL-FT-30-70CRI-IL	0.900	63	20	B1-U0-G1
+	1	W	Single	LSI XTOR8B-Y	0.900	81	20	B1-U0-G1
+	1	W1	Single	LSI XTOR4B-Y	0.900	37.7	15	B2-U0-G0

Luminaire Location Summary						
LumNo	Label	X	Y	Z	Orient	Tilt
1	C	2251001.5	1426680.3	15.75	350	0
2	C	2250998.184	1426660.577	15.75	350	0
3	C1	2250818.8	1426677.2	15.75	170	0
4	C1	2250814.953	1426657.573	15.75	170	0
5	S	2250794	1426600.8	20	170	0
6	S1H	2250837.1	1426770.2	20	323	0
7	S1H	2251055.2	1426638.1	20	170	0
8	SH	2251026.7	1426551.7	20	170	0
9	SH	2250920.7	1426810.8	20	260	0
10	SH	2250999.5	1426796.8	20	260	0
11	SH	2250782.7	1426696.7	20	323	0
12	W	2250995.8	1426732.3	20	350	0
13	W1	2250973.7	1426608.3	15	350	0

Calculation Summary							
Label	CalcType	Units	Avg	Max	Min	Avg/Min	Max/Min
Property Line	Illuminance	Fc	0.03	0.4	0.0	N.A.	N.A.
Parking & Drives	Illuminance	Fc	1.83	4.4	0.5	3.66	8.80

FOOTCANDLE ANALYSIS BY PHOTOMETRICS LLC 4/19/2023.

ALL LIGHTS ARE FULL CUTOFF WITH FLAT GLASS LENSES AND NO TILT.
ALL LIGHTS HAVE 3000K COLOR TEMPERATURE.
POLE LIGHTS ARE MOUNTED 20FT ABOVE FINISHED GRADE.
WALL LIGHTS ARE MOUNTED 15FT & 20FT ABOVE FINISHED GRADE.

THIS LAYOUT MEETS IES RP8-18 RECOMMENDATIONS FOR BASIC PARKING LOT LIGHTING LEVELS AND UNIFORMITY.

LIGHTING MEETS Sec. 27-250. - Regulations, (c), (7) Parking areas - 0.4fc minimum + 4:1 Ave/Min Uniformity.

FOOTCANDLE READINGS DO NOT INCLUDE SHADOWING EFFECTS CAUSED BY OBSTRUCTIONS ONSITE SUCH AS BUILDINGS, TREES, ETC.

THE IES PHOTOMETRIC COMPUTER FILES USED FOR THIS ANALYSIS WERE PROVIDED BY THE MANUFACTURER(S) OF THE LIGHT FIXTURE(S) USED ON THIS PROJECT. THE ACCURACY OF THESE FILES ARE THE RESPONSIBILITY OF THE MANUFACTURER(S).

CONFORMANCE TO ANY AND ALL FACILITY, LOCAL, STATE, OR NATIONAL CODES AND REQUIREMENTS IS THE RESPONSIBILITY OF THE OWNER AND/OR THE OWNER'S REPRESENTATIVE.

CAREFUL PLACEMENT AND ORIENTATION OF THE LIGHT FIXTURES ONSITE IS REQUIRED FOR THIS COMPUTER SIMULATION TO BE ACCURATE.

NORMAL TOLERANCES OF VOLTAGE, TEMPERATURE, LAMP OUTPUT, AND BALLAST AND LUMINAIRE MANUFACTURER WILL AFFECT RESULTS.

Photometrics LLC
2129 Chinook Tr
Maitland, FL 32751
(407) 330-8220

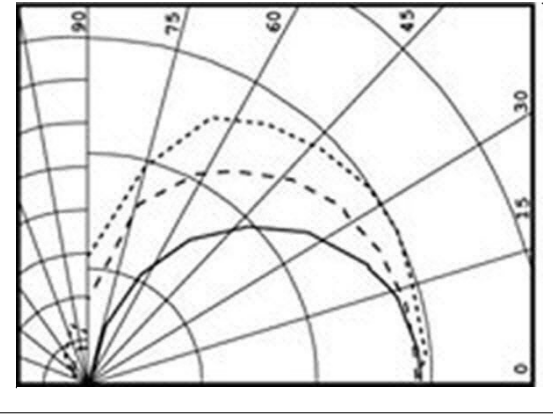

#	Date	Comments

Revisions	

GEORGETOWN SELF STORAGE
4470 CHAMBLEE DUNWOODY RD
DUNWOODY, GA

Photometric Plan

Scale: 1"=30' (at 24"x36" Print Size)

Draen By: BV
Checked By:
Date: 4/19/2023









Exhibit B, Renderings Submitted July 27, 2023



